

See last scientific articles devoted Russian fluorine chemistry in online magazine "Fluorine notes".

[http:// www. fluorine. ru/Notes](http://www.fluorine.ru/Notes)

## MAIN TRENDS IN INDUSTRIAL FLUOROCOMPOUNDS DEVELOPMENT

*B.N. Maximov RSC "Applied Chemistry", 197198, 14 Dobrolubov ave., St. Petersburg, Russia*

Further development and implementation of HFC-32, 23, 152a, 134a, 125, 227 and PC-218, 318c, etc. technologies are carried out in order to comply with the Montreal Protocol on the ozone-depleting substances (ODS).

Also in these studies much attention is being paid to the blends of hydrofluorocarbons (HFCs), fluorocarbons (FCs) and hydrocarbons with thermophysical and thermo-dynamic properties close to those of chlorofluorocarbon-12 (CFC-12) or hydrochlorofluoro-carbon-22 (HCFC-22) but their application does not require to change the compressor oil. So that these blends may be recommended as drop-in ODS substitutes. The study also focuses on the search of ODS substitutes for various applications: solvents, refrigerants, fire extinguishants. We are investigating for this purpose such new fluorine-containing substances as perfluoroalkyliodides (FIC), fluorinated ethers (HFE), etc., both pure or blended with HFCs.

Modern industry need in polymer materials makes it very important to investigate olefins containing fluorine and oxygen, such as perfluoroalkylvinyl ethers, hexafluoro-propylene oxide, etc. Another wide group of fluorine-containing surface-active substances for various applications is also of more and more growing interest. That is why we go on studying them and trying to choose the best and the most suitable for industrial production.

## CHEMISTRY OF FLUORINATED SMALL-SIZED CARBOCYCLIC COMPOUNDS

*O.M Nefedov, N.V. Volchkov*

*Zelinsky Institute of Organic Chemistry, Russian Academy of Sciences, Leninsky Prospect, 47, Moscow 1 17913, Russia.*

A traditional approach to the synthesis of fluoroorganic compounds based on a direct introduction of fluorine atoms into organic molecules via addition or replacement reactions with inorganic fluorinating reagents. Alternative strategy consists in a constructing of fluorinated structures using fluorine-containing building blocks. Polyfluoroolefins and fluorocarbenes easily generated from commercial freons may be used as available building blocks for this synthetic approach. These synthons react with unsaturated organic compounds to form three- and four-member carbocyclic adducts which can be undergo ring opening reaction to give a variety of fluorinated structures.

The synthetic and mechanistic aspects of various ring-opening and ring-expansion of fluorinated cyclopropanes, cyclobutanes and cyclobutenes such as cyclopropyl - allylic isomerization, dihalogeno-bicyclo[3.1.0]hexen - halogenobenzene transformation, vinylcyclopropane - cyclopentene rearrangement, vinylcyclobutane - cyclohexene isomerization, cyclobutene - butadiene interconversion are discussed in the lecture. Some useful reactions of fluorinated cyclobutanes and cyclobutenes proceeding without ring- opening are also considered. The successes and perspectives of the application of these reactions for the preparative and industrial synthesis of fluoroaromatics, fluoroalkenes, fluorodienes and fluoroquinolones (antibacterial agents) are discussed.

## **CREATION OF HYDROFLUOROCARBONS PRODUCTION CAPACITIES IN RUSSIA**

V.G. Barabanov, B.N. Maximov, G.F. Tereschenko RSC "Applied Chemistry", 14 Dobrolubov ave., 197198, St.Petersburg, Russia

The conversion of industrial sector to non-ozone-depleting substances (NODS) requires first of all to create manufacture of ozone-depleting substances (ODS) alternatives for such applications as refrigerants, foaming agents, aerosol propellants, solvents and fire extinguishants.

According to the results of the special studies both in Russia and in other developed countries the most efficient ODS (HFC-II, -12, -113, -114, -13, -502, Halons 2402, 1301, 1211) alternatives are: hydrocarbons, water, ammonia, 1,1,1,2-tetrafluoroethane (HFC-134), pentafluoroethane (HFC-125), 1,1-difluoroethane (HFC-152a), difluoromethane (HFC-32), 1,1,1-trifluoroethane (HFC-143a), trifluoromethane (HFC-23), etc.

At Russian Scientific centre "Applied Chemistry" we have developed a number of NODS manufacture technologies, such as: HFC-134a, -125, -32, -152a, -23 etc. RSC "Applied Chemistry" in cooperation with Russian Ministry of Economy and ODS-producing chemical plants have developed a plan to create these NODS production complex in Russia.

HFC-125 manufacture is started at JSC "Halogen", HFC-152a manufacture is started at JSC "Kaustik", HFC-23 manufacture is started at RSC "Applied Chemistry". A number of other NODS production capacities are now being created at Russian chemical plants.

## **PROSPECTS FOR DEVELOPMENT OF OZONE-SAFE REFRIGERANTS PRODUCTION AT THE ENTERPRISES OF MINATOM OF RUSSIA**

A.N.Golubev, A.S.Dedov, V.Yu.Zakharov, S.V.Malyshov, V.T.Orekhov, V.V.Shatalov, V.A.Tsarev All-Russian Research Institute of Chemical Technology Joint Stock Company Kirovo-Chepetsky Khimichesky Kombinat

After Montreal protocol has been adopted the enterprises of Minatom of Russia are carrying out intensive researches to find the new ways of ozone-safe substances synthesis. One of the main directions of the research works is to use depleted uranium hexafluoride as fluorinating agent, large quantities of uranium hexafluoride have been stored at the enterprises of Minatom of Russia and the problem is how to transfer them to other more ecology safe form.

The main advantages of the technologies on base of uranium hexafluoride - the processes take place in gas phase under normal pressure and moderate temperatures.

Solvents khladon-122a, 132c, refrigerants 116, 125, 134a, 143a, 218 have been synthesized at pilot plants or preseries plants.

Feasibility studies presented good prospects for the development of these technologies.

Research works on khladon-134, the component of prospective refrigerants SM-1, were carried out.

The results of the developments have been represented in the project of Russian federal program on ozone safe substances.

## **POLYFLUOROAROMATIC DERIVATIVES OF IV - VI GROUP ELEMENTS AS SYNTHONS FOR POLYFLUOROARYLATION**

V. V. Bardin, G.G. Furin Institute of Organic Chemistry, 630090 Novosibirsk, Russia

The concept of the nucleophilic polyfluoroarylation based on the polyfluoroaromatic derivatives of IV-VI Group elements as synthons is elaborated. I

The transfer of polyfluoroaryl group from  $(C_6F_5)_nSiMe_{4-n}$ ,  $C_6F_5GeEt_3$ ,  $(C_6F_5)_nM$  ( $M = P, As, Sb, Bi, Te$ ) to highly electrophilic polyfluorinated alkenes, cycloalkenes, azalkenes and aromatics proceeds easily under nucleophilic catalysis with fluoride anion in polar aprotic solvents. All  $C_6F_5$  groups of  $(C_6F_5)_nMR_m$  are involved in these reaction while alkyl groups of  $(C_6F_5)_nSiMe_{4-n}$  and  $C_6F_5GeEt_3$  are not transferred.

The relative reactivity of  $(C_6F_5)_nMR_m$  is discussed.

This common approach allows to choose the appropriate polyfluoroaromatic synthon for polyfluoroarylation of the desirable electrophilic reagent.

## **FLUOROPOLYMERS IN RUSSIA. DEVELOPMENT, PRODUCTION AND FUTURE PROGRESS**

*V. V. Konovalenko, N.N. Loginova, S. V. Tirnofeev, A.K. Pugachev, L. V. Vishnyakova AO "Plastpolymer", 195108, 32 Polyustrovsky pr., St. Petersburg, Russia*

50 years ago JSC "Plastpolymer" started to develop fluor-containing polymers in Russia due to intensive development of atomic, aviation and cosmic industries. In 1948 first laboratory samples of polytetrafluoroethylene were prepared and in a year a pilot plant for the production of this polymer was organized. Then JSC "Plastpolymer" developed chlorotrifluoroethylene and polymer on this basis.

Successful development of vinylidene fluoride, hexafluoropropylene, perfluoroalkyl vinyl ethers and some other fluor-containing monomers allowed JSC Plastpolymer to develop methods for the preparation of fully fluorinated polymers and polymers containing in addition to fluorine other substituents, namely: hydrogen, chlorine, perfluoroalkoxy radicals. Some methods have been developed to control molecular weights and compositions of fluoropolymers.

Original processes have been developed for the production of polytetrafluoroethylene, polychlorotrifluoroethylene, polyvinylidene fluoride, copolymers of tetrafluoroethylene, chlorotrifluoroethylene and vinylidene fluoride with non-fluorinated, fluorosubstituted monomers and with monomers containing various functional groups.

Simultaneously with the organization of the production of fluoropolymers processing methods have been developed to produce primitive products from polytetrafluoroethylene by free sintering of preforms, high strength chemical resistant clothes and unique products for medical purposes, insulating films and tubes, foil high frequency dielectrics and multilayer perfluorinated ion exchange membranes.

A wide range of compounds, varnishes, dispersions, adhesive fluoropolymeric film materials and perfluorinated ion exchange membranes has been developed. The presentation considers modern state of the production of fluoropolymers in Russia and abroad, volumes and consumptions. The increase of capacities for various kinds of fluoropolymers has been studied. The increase of capacities for the production of fluoropolymers is compared with their consumptions.

Although fluoropolymers are 50 years old they continue to be non-replaceable in those applications where they are used, their applications extend, the future of these materials is enough attractive. The development of new fluor-containing polymers has been studied, promising applications are mentioned for existing and new fluoropolymers.

## **CREATION OF FACILITIES FOR INDUSTRIAL PRODUCTION OF FLUOROPLASTICS AND ARTICLES ON THEIR BASE ON KIROVO-CHEPETSKY KHIMICHESKY KOMBINAT**

*A.K. Denisov, A.S. Dedov, V. Yu. Zakharov, A.I. Masljakov*

*JSC "Kirovo-Chepetsk Khirnkombinat" 613020, Russia, Kirovskiy dist., g. Kirovo-Chepetsk, Pozharnyy st. 7*

Organization of fluorine hydride and fluor production on Kirovo-Chepetsky Khimichesky Kombinat appeared to be the base for creation of new branch of industry - i.e. production of khladones, monomers, fluoroelastomers and articles, produced on their base. Engineering developments of RSC "Applied Chemistry" and JSC "PLASTPOLYMER" (St.Petersburg) were used as the base for industrial production of khladones, monomers, fluoroelastomers and articles on their base.

Exclusively valuable properties inherent to these organic products provide their successful use practically in all branches of industry. \

Facilities for production of fluoroplast-4 were organized in 1956, complex facilities for fluorocopolymers and fluoroelastomers production were commissioned in 1961, production of articles on fluoroplastics base was organized in 1964. I

Nowadays kombinat produces fluoroplasts of 21 types (F-j 4, F-4D, F-40, F-4MB etc.), fluoroplastic suspensions of 5 types (F-4D, F-4DB, etc.), fluorine rubbers of 4 types \ (SKF-26, SKF-32 etc.), latexes of 2 types and FPR lacquer. j

In cooperation with JSC "PLASTPOLYMER" production of a number of articles including: tubes, bushes, rods of precise dimensions, SKL film, FUM tape, fluoroplast-4 (F4K20, F4K15M5) based composite materials and articles produced by moulding was successfully organized. Kombinat produces over 1500 types of articles of various sizes.

Kirovo-Chepetsky Khimichesky Kombinat is the leading producer and concerning the number of types of its products which meet the demands of a number of branches oil industry, it is the only producer of high quality fluoroplasts and fluorine rubbers in the country.

## **THE INTERRELATION OF COMPOSITION - STRUCTURE - PROPERTIES - APPLICATIONS IN THE SERIES OF FLUORCONTAINING POLYMERS**

*N.N.Loginova, P.S.Zakharov*

*JSC Plastpolymer, Polyustrovsky pr., 32, 195108, St. Petersburg*

Scientific aspects and informational material of applied nature have been presented, they relate to the interrelation of composition - structure - properties -applications in the series of fluorocontaining homo-, co- and terpolymers. New approaches to the evaluation of properties by computer softwares have been also considered.

As it is known, fluoropolymers (FP) are characterized by high thermal and chemical resistance, excellent electrical properties, antifrictional and antiadhesive properties explained by the presence of fluorine atoms in the macromolecule.

The series of homopolymers of fluorsubstituted ethylenes is characterized by the proportional relation of some properties ( specific gravity, Tmeit, Tdecomp., electric strength, chemical resistance) and the number of fluorine atoms in the monomer unit. In case of co- and terpolymers the defining role, from the point of view of the properties, belongs not as much to the composition but to the arrangement of elementary units of the macromolecule and the above-molecular structure of the polymer, it is demonstrated by the extreme relation of the properties of TFE and VDF copolymer and the ratio of comonomers as well as by the difference of the properties of the copolymers of TFE with E and TFE with VDF with similar elemental compositions.

The behavior of fluoropolymers of various compositions and structures under thermal effect is considered. The difference of degradation mechanisms is shown. For perfluorinated polymers they are carried out by aepolymerization type and for fluorohydrogen containing ones they are a

combination of the reactions of dehydrofluorination, structurization and depolymerization, they are defined by the composition and structure of FP including the end group.

A possibility has been demonstrated for the significant variation of the properties of FP by using similar monomers for binary and tertiary systems. The effect of the addition of carbon-oxygen bond to FP macromolecule has been studied.

A new approach is proposed to evaluate the effect of various factors and to predict the results of external effects on the properties of FP using the example of the studies of thermal stability and of physico-mechanical properties of FP. The computer search of the relation of the properties and the effect of heat flow or corrosive fluid in the form of surface diagrams makes easier to take a decision concerning the selection of the material for concrete operating conditions.

## **FLUOROCOPOLYMERS WITH FUNCTIONAL GROUPS AND THEIR PRODUCTS**

*S.V. Tirnofeev, A.I. Andreeva, L.P. Bobrova, Yu.A. Zaichenko, V.V. Konovatenko JSC  
Plastpolymer, 32 Polyustrovsky pr., 195108, St. Petersburg*

The presence of reactive groups in fluoropolymer structures provides wide possibilities for the modification of their structure and properties and gives new applications of their products. We have considered scientific basis for synthesis, structure and properties of two classes of fluorocopolymers with functional groups:

- a) copolymers of tetrafluoroethylene and perfluoro-vinyl ethers containing sulfonyl fluoride groups (I);
- b) copolymers of trifluoroethylene with hydrocarbon vinyl ethers containing hydroxy groups (II).

Copolymers I are the basis for the preparation of perfluorinated sulfocationic membranes which are widely used by various industries, namely membrane electrolysis, chemical sources of energy, organic synthesis (as a superacidic catalyst). These membranes have unique chemical stability and thermal stability (they are resistant to concentrated acids, hydroxides, oxidizers at max. temperature of 100°C), high conductivity, mechanical strength, hydrophilicity.

This presentation includes the results of studies for modification of copolymers I in the process of polymer similar transfers (interactions with hydroxides, amines), for structures of copolymers and membranes by X-ray, IR, DSC. The effect of the composition of copolymers (number of functional groups) on the morphology (cluster model), electro-chemical, diffusion and hydration performances of perfluorinated membranes is shown.

Copolymers II are the basis for the preparation of varnishes and enamels which provide high properties of protective coatings (weather stability, dust- and moisture- stability, long-term stability).

The presentation includes the results of studies of the effect of the nature of monomers and of the composition of copolymers on their physico-chemical properties. A possibility has been demonstrated to cure copolymers by reactive hydroxy groups using diisocyanates. The results are given for the modification of copolymers I with the aim to provide temperature cross-linking of macromolecules in the absence of cross-linking agent.

## **CHEMISTRY OF VULCANIZATION OF FLUORO ELASTOMERS**

*Z.N. Nudelman*

*Scientific Research Institute of Elastomeric Materials and Articles Industrial Research Firm  
RIAS Ul. Malaya Trubetskaya 28, Moscow, 119868, Russia*

Copolymer of perfluoro propene (PFP)- vinylidene fluoride (VF - SKF-26 fluoro rubber, and trifluorochloro ethylene(TFCE)-VF copolymer (SKF-32) are used in Russia for rubber technical articles production working in different mediums at temperatures to 300°C.

The dissociation energies and polarity of C-H, C-F and C-Cl bonds control vulcanization characteristics of mentioned copolymers. It is improbable the realization of the homolytic reactions of PFP-VF copolymer due to high energy (C-H about 480 and C-F 560 kJ/mol). Therefore a heterolytic systems mainly bis-phenols and phase transfer catalysts are used for vulcanization of this copolymer. The efficiency of different catalysts was investigated. Some elements of action mechanism has been studied with NMR and chromato-mass- spectrometry methods. The dependence of vulcanization rate and technical properties of vulcanized rubbers on some properties of ingredients has been showed.

The dissociation energy of C-Cl bond is about 370 kJ/mol. Thus the VF-TFCE copolymer can react by homolytic pathway. The "medon-complect" vulcanizing system is worked up [1]. In this system active zero valency copper is the initiator of free radical reaction of vulcanization. The mechanism reaction is studied including elimination Cl atoms from copolymer. As result the polymer radicals is formed and the latter cause a cross-linking with suitable radical acceptor. The non efficient termination of vulcanization chain is substantially smaller in comparison with peroxide system.

All new vulcanizing agents are being realized in industry.

1. Nudelman Z.N., Lavrova L.N., Russian Patent No 2071489,1997

## **SOME ASPECTS OF PHYSICAL AND CHEMICAL MODIFICATION OF POLYTETRAFLUOROETHYLENE (PTFE)**

*A.K. Pugachev*

*JSC Plastpolymer, Polyustrovsky pr., 32, 195108, St. Petersburg*

PTFE occupies dominating position among fluoropoly-mers by its production volume and by its complex of properties. However very high melt viscosity, high deformation under load, low wear resistance, low surface energy make difficult its processability and prevent from complete realization of the properties of this material in actual machines and apparatus.

Chemical and physical modification allow not only to increase these properties but also to impart new properties which are not characteristic for PTFE. The methods of modification include an addition of small amounts of perfluorinated monomers (hexafluorpropylene, perfluor-methyl propyl ether) to tetrafluorethylene chain. This modification allows to increase physico-mechanical, electrical properties, creep resistance and opens new process possibilities to produce finished products and also improves weldability of PTFE. Chemical modification also includes surface treatment with sodium complex to impart adhesion to PTFE to produce various laminates.

More important variation of the properties of PTFE takes place when physical methods are used, e.g. addition of various fillers and stretching. In case of filling the complex of properties is increased that is important for friction units:

*Wear resistance is increased 1000 times*

*Load deformation is decreased 2,5 times*

*Heat conductivity is increased 3 times*

*Thermal expansion factor is decreased 2 times*

Besides, by adding fillers it is possible to impart new properties - electroconductivity, magnetic properties. Stretching is used to increase mechanical, electrical and thermal shrinking properties of films. Traditional materials of this type include electroinsulating and capacitor films.

High results have been achieved by stretching in the processing of dispersible PTFE. New porous materials and products have been prepared using stretching and special methods for heat treatment. Their strength is 6-7 times higher than that of PTFE, they have excellent dielectric properties when porosity reaches 90%. These materials are widely used for insulation of radio frequency cables, prostheses of vessels, ultrafilters, breathing clothes and packings. Chemical and physical methods of modification and combination of both allow to change directly that complex of properties which is required by the application.

## **SOME ASPECTS OF PERFLUOROORGANIC COMPOUNDS TECHNOLOGY**

*G.I. Kaurova, P.P. Moldavsky. G.G. Furin*

*RSC "Applied Chemistry" 14 Dobrolubov ave., 197198, StPetersburg, Russia*

Perfluororganic compounds (paraffins, ethers and tertiary amines) are used in very different fields of industry due to their exclusive thermal and chemical stability, excellent thermal and dielectric properties.

But they have no wide application because there is no efficient production technology. The main methods of their production are: interaction of hydrocarbons (paraffins, ethers) with higher fluorides of metals and electrochemical fluorination of hydrocarbons (ethers, tertiary amines). Both these methods have low yield and productivity, great amount of wastes which are difficult to utilize.

Our investigations compatible with literature data have shown that the compounds containing one or several atoms of fluorine are able to be fluorinated to perfluoro- compounds with high yields. Besides a possibility to use elementary fluorine in production technology of per-fluorocompounds appears.)

But the assortment of partially fluorinated compounds produced in industry is very limited. There are perfluoro-olefins, mainly  $C_2F_4$  and  $C_3F_6$ , some quantity of  $C_4F_8$ , also dimer and trimer of hexafluoropropylene  $C_6F_{10}$  and  $C_9F_{14}$ .

We have developed the production methods for some perfluorinated olefins, particularly perfluoropropene-2, also fluorine-containing ethers and tertiary amines by interaction of perfluorinated olefins with alcohols and secondary amines accordingly.

Fluorination of perfluorinated olefins, partially fluorinated paraffins and ethers by elementary fluorine allows to produce perfluorinated paraffins and ethers with high yields (50-99%). Fluorination of fluorine-containing enamines seems less successful because the yields of the goal products do not exceed 6%. But these compounds are easily fluorinated electrochemically, the output of

goal products is as great as 80% in this case. Any method of fluorination brings numerous impurities along with the goal products. The main group of admixtures (the most difficult to separate) are compounds containing 1-3 atoms of hydrogen. In some cases their amount is as great as 30%. Their properties are close to perfluorinated compounds but they are able to eliminate hydrogen fluoride under tough conditions. The quality of the goal products is deteriorated by presence of those admixtures which decrease dielectric characteristics and increase corrosion activity.

Hydrogen-containing admixtures may be destroyed by alcohol alkalies or additionally fluorinated to perfluorinated compounds. Fluorination is carrying out under enough strong conditions, on catalysts, the best of them is trifluoride of cobalt for our opinion.

During investigation of different physicochemical properties of perfluorinated compounds (boiling point, viscosity, solubility of gases in them, dielectrical properties) we have found out

that these properties depend on the length of the carbon chain and slightly depend on the structure. This fact allows to consider them as one class. This assumption results in two important consequences.

The first is interchangeability of perfluororganic compounds when they are used in equipment. The second important consequence is change in quantity criteria of perfluororganic compounds. The perfluororganic compounds independently on the structure have similar properties and the presence of hydrogen-containing compounds and olefins deteriorates exploitation properties. That is why it is necessary to determine the quantity of these admixtures during quality evaluation, in this case the index ((content of main substance)) becomes less important and in number of cases may be changed by another ones as follows: distillation limits, viscosity, density and so on.

## Comparative mobility of nitro group and fluorine displacements in aromatic derivatives

V. M. Vlasov., A.A. Tabatskaya, O.Yu. Rogozhnikova and I.A. Khalfina

*Novosibirsk Institute of Organic Chemistry, 9, Lavrentjev Ave., 630090  
Novosibirsk, Russia.*

It is well known that nitro group and fluorine are the best leaving groups in activated aromatic nucleophilic substitution reactions and their relative mobility depends on a nucleophile and substrate nature very strongly [1]. However there is scarcely any data and relative mobility of nitro group and fluorine in low activated arenes, for instance, in meta-benzene derivatives. The relative mobility of nitro group and fluorine in 3-R-5-R'-nitrobenzenes (1) by the action of charged N-, O- and S- nucleophiles with no by-products in the reaction (1) was studied [2]. The changes in nitro group and fluorine mobility depending on the nucleophile attack at an unsubstituted position in a different substrates, an influence of substituents R and R' on the nucleophile attack at ipso-position, and a nucleophile nature are discussed. Synthetic possibilities of the reaction (1) are also discussed [3].

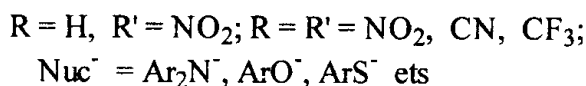
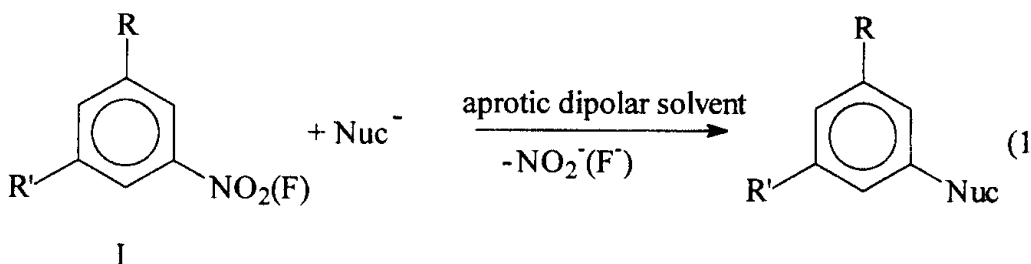

This work was supported by the Russian Foundation for the Basic Research (grant N 95-03-08772a).

1. F. Terrier, *Nucleophilic aromatic displacement: influence of the nitro group*, VCH, Weinheim (1991), Ch.1.

2. I.A. Khalfina, O.Yu. Rogozhnikova and V.I Vlasov, *Zh. Org. Khim.* 32 (1996) 1371

3. A.A. Tabatskaya, V.M. Vlasov, Zh. Org. Khim.]  
(1996) 1820.

## **MECHANISM OF RADIATION DESTRUCTION OF LINEAR PERFLUORALKANES AND POLYTETRAFLUOROETHYLENE**

*S.R. Allayarov, L.P. Kirn, D.A. Gordon  
Institute of Chemical Physics in Chemogolovka of RAS*

A dependence of radiolysis mechanism of n-perfluoroalkanes (n-PFA) on their chain lengths has been investigated using such compounds as n-C<sub>6</sub>F<sub>14</sub>, n-C<sub>8</sub>F<sub>18</sub>, n-C<sub>12</sub>F<sub>26</sub>, n-C<sub>16</sub>F<sub>34</sub> and polytetrafluoroethylene (PTFE). In the course of their radiolysis the accumulation of radicals with closely spaced radiation-chemical yields takes place (G turned out to be of about 1,8 (±) 0,6/100 ev for n-PFA and 0,4/100 ev for PTFE). The overlapping of at least three kinds of radicals: -CF<sub>2</sub>-CF<sub>2</sub>CF<sub>2</sub>-, -CF<sub>2</sub>CF<sub>2</sub> and CF<sub>3</sub> can be observed in the ESR spectra of irradiated at 77K n-PFA. The parameters of these radicals for n-PFA and PTFE at 77K practically coincide. The absorbed dose dependence of -CF<sub>2</sub>CF<sub>2</sub>CF<sub>2</sub>- and -CF<sub>2</sub>CF<sub>2</sub> radicals' relative concentrations of exposed to radiation at 77K n-C<sub>12</sub>F<sub>26</sub> and n-C<sub>16</sub>F<sub>34</sub> samples has been determined. A proportion of these radicals remains the same up to dose 0,4 kGy being the evidence of insignificant effect of reaction products on the radiolysis mechanism of n-C<sub>12</sub>F<sub>26</sub> and n-C<sub>16</sub>F<sub>34</sub>. The chromatographic analysis of radiation destruction products of four linear n-PFA has shown their radiolysis led to identical compounds such as lowmolecular n-PFA, perfluoroolefins and in small amounts more highmolecular n-PFA than initial ones. The radiation-chemical yield of n-C<sub>12</sub>F<sub>26</sub>, n-C<sub>16</sub>F<sub>34</sub> breakdown has been calculated. It is important that this value declines with absorbed dose in the same way as PTFE molecular mass changing in the course of its radiation destruction.

The radical accumulation kinetics has been explored for PTFE and its carbohydrate analog - polyethylene (PE) during their lowtemperature radiolysis. The initial radiation-chemical yield of radicals for irradiated PE turned out to be of about 10-12/100 ev, what is more than PTFE radiation-chemical yield by factor more than twenty. Similar difference has been observed for lowmolecular analogs such as n-C<sub>7</sub>H<sub>16</sub> and n-PFA as well. More probably that the low yield of radicals and high level of PTFE macromolecules destruction in the case of PTFE is connected with reactions of fluorine atoms formed in the course of radiolysis. On one hand, the low yield of radicals in comparison with PE is a result of stabilized radicals recombination with fluorine atoms formed during theradiolysis, on the other hand, it is connected with the fluorine atom detachment from PTFE macromolecules by these atoms reaction. More important role in PTFE main chain breaking down stabilization plays recombination reaction of fluorine atoms «in cell» with radical pairs formed by C-C bond breaking.

Summation of obtained results displays to lessen the destruction of main carbon chain during the radiolysis of PTFE it is necessary to embed into polymer macromolecule the fluorine monomers involving double bonds.

## **SPECIFIC FEATURES OF ELECTROCHEMICAL FLUOROALKYLATION OF GASEOUS OLEFINS BY FLUOROCARBONIC ACIDS**

*Russian side -A.A. Krasynnikov, G.I. Kaurova, V.G. Ternchenko; 3 M side - .Craig Barton*

The results of investigations were reviewed on the electrochemical fluoroalkylation of gaseous olefins by fluoro-carbonic acids.

As the anode material the glassy carbon (GC) was used, which has advantages in comparison with Platinum and can be regarded as a perspective material for the creation of industrial technologies of electrochemical synthesis of fluoroorganic compounds. The experiments were carried out in the specially developed electrolyser of the high pressure.

On the basis of the obtained experimental material the regulations of electrochemical fluoroalkylation were studied:

- a) in the row of linear perfluoroacids  $C_nH_{2n+1}COOH$  ( $n=1-4$ ) - on the example of ethylene fluoroalkylation;
- b) at the adding of fluorine atoms to the olefin molecules - on the example of ethylene fluoroalkylation, difluoroethylene (M-2) and hexafluoroethylene (M-6) by acids  $CF_3COOH$  and  $HCF_2COOH$ ;
- c) at the replacement of one Fluorine atom for Hydrogen in the molecule of perfluoroacid - on the example of ethylene fluoroalkylation by acids  $C_2F_5COOH$  and  $HCF_2COOH$ ;
- d) at the increasing of the length of olefin carbon chain -on the example of ethylene and propylene fluoroalkylation by the acid  $C_3F_7COOH$ ;
- e) at the adding of Chlorine atoms to the olefin molecule - on the example of ethylene and vinyl chloride trifluoromethylation;
- f) in the process of using of olefins with the linear and branched carbon chains - on the example of fluoroalkylation of butylene and isobutylene by the acid  $C_8F_{17}COOH$ .

Reaction products were identified by the method of chromatomass-spectroscopy and GLC. Some of the most interesting for us compounds, for example,  $C_2F_5CH_2CH_2C_2F_5$ ,  $C_3F_7CH_2CH_2C_3F_7$  were isolated by rectification under the vacuum with the purity more than 95%.

The obtained results enabled to define the specific features of the described method of fluoroorganic compounds synthesis and evaluate its possibilities.

## **REDUCTIVE ACTIVATION OF POLYFLUOROARENES**

*S.S.Laev, L.N..Shchegeleva, I.V.Beregovaya, G.A.Selivanova, V.F.Starichenko, V.D.Shteingarls,  
Novosibirsk Institute of Organic Chemistry, Siberian Division of RAS, 630090 Novosibirsk,  
Russia*

Perfluoroarenes can be easily prepared but partially or polynuclear Anorinated arenes are less accessible whereupon the reductive activation of polyfluoroarenes is of great synthetical significance. Mechanistically, this is tightly connected with electronic structure and reactivity of polyfluoroarene radical anions. This presentation deals with polyfluoroarene reductive activation for the C-F bond dissociation and dimerization.

For polyfluorobenzoic acids as model substrates, the regularities of reductive hydrodeAurination have been investigated by using physical and chemical approaches. The dependence of reaction rate on the number and location of fluorine atoms as well as regioselectivity of the reduction by metals have been revealed and was subjected to a quantum chemical analysis in the framework of pseudo-Jahn-Teller effect theory linking the easiness of

radical anion fragmentation to an efficiency of the vibronic interaction between its ground II- and excited S\*-state with odd electron located mainly on the respective C-F bond. Also the solvation effects should be taken into account for correct rationalization of ortho to meta fragmentation rate ratio.

The reductive activation of polyfluoroarene carbonitriles for fragmentation and dimerization has been also investigated by means of ESR spectroscopy and quantum mechanical method outlined above. The complete set of fluorinated nitrobenzenes as well as para-substituted 2,6-difluoro- and tetrafluoronitrobenzenes has been shown by ESR and electrochemical methods to give relatively stable radical anions and the regularities relating electronic structure and stability of these species with a number and location of substituents as well as medium composition have been revealed.

The reductive activation of the diversity of polyfluoroarenes is applied for the development of the methods of selective hydrodefluorination in the framework of solving a general problem of transformation of easily attainable perfluoroarenes into less accessible partially fluorinated compounds. The synthetic method have been advanced based on the usage of metals and ammonia containing media.

## **PROGRESS IN SEPARATION AND PURIFICATION TECHNOLOGIES OF FLUOROCONTAINING PRODUCTS IN RSC "APPLIED CHEMISTRY"**

*Boris Nikiforov*

RSC "Applied Chemistry", 197198, St.Petersburg, 14, Dobrolubov ave., Russia

Perfection of purification technologies of basic fluororganic products including ozone safe refrigerants HFC134a, HFC125, HFC32, HFC152a, fluoromonomers tetrafluoroethylene and hexafluoropropylene remained by one of primary directions of activity in the field of separation and purification in the RSC "Applied Chemistry".

Development of purification processes of several new HFC products such as HFC227ea, HFC245fa and others also was fulfilled from the time of previous conference. As similar to refrigerants of ethane row, azeotropic admixtures accompany to aim products that seriously complicates purification of these products. However, in all cases purification became possible with using selective methods of separation.

As a rule, optimization of separation stages on existing facilities gave significant reduction of energy expenses. It was achieved by improvement of technological process, reduction of reflux ratios of distillation columns, using selective methods of separation (absorption, extractive and azeotropic distillation, adsorption etc.), using complete columns (with several feed points and side products) instead of several ordinary columns.

Optimization of technologies demands conducting precise simulation based both on exact algorithms and reliable experimental data. For this purpose investigations of basic properties of products and mixtures, first of all of phase equilibria, were continued, new computer programs for precise simulation of separation processes were designed. As a result, for instance, in modified technologies of tetrafluoroethylene and hexafluoropropylene the number of distillation columns was decreased, energy expenses were reduced.

Significant attention was paid to development and improvement of separation processes for fluorocontaining products with functional groups. In particular, original method of isolation of trifluoroacetic acid from water solutions including extraction of aim product by fatty acids was proposed.

Now large significance has production of extra pure fluorocontaining products. In this connection, investigations were continued for technologies of electronic grade (with purity more than 99.99%). HFC23, FC318C, FC116 and other products. Essential attention was paid to preparation of equipment, to choice of materials contacting refined products. Lots of such products were got in the Pilot Plant of RSC Applied Chemistry".

As a rule, energy optimization, purification of products in complete columns, obtaining extra pure products are connected with use of mass transfer equipment of high efficiency. Such equipment is designed, industrial mass transfer packing with efficiency up to 8 theoretical plates per meter are produced in RSC "Applied chemistry".

## **DEVELOPMENT OF INDUSTRIAL TECHNOLOGY OF PENTAFLUOROETHANE MANUFACTURE**

*Y.G. Trukshin, S.K. Sheremetyev, V.F. Denisenkov, A.N. Firsov, V.Y. Shubin, V.G. Gavrilov, N.Y. Samsonova, O.N. Molchanov, V.G. Barabanov*  
*ISC "Halogen", 614113, Perm RSC "Applied Chemistry", 14 Dobrolubov ave., 197198, St. Petersburg .Russia NTF "Kornkon", 14 Dobrolubov ave., 197198, St. Petersburg, Russia*

Gas-phase catalytic hydrofluorination of perchloroethylene was chosen to develop the industrial process of pentafluoroethane manufacture because it uses cheap and easily available raw materials.

Chrome-magnesium fluoride catalyst was proved to be the most efficient for this process. Pentafluoroethane synthesis can be started either from perchloroethylene or from pentafluoroethane blended with partially fluorinated products (tetrafluorochloroethane, trifluorodichloroethane, difluorotrichloroethane). It is possible to carry out the process in one reactor or to use a system consisting of two reactors. Yet the one-reactor scheme is preferable for industrial applications because it is the most simple to maintain and consumption of expensive materials (steel XH78T, X18HIOM2T) related with the synthesis unit mounting is lower. During the progress of the research work it was shown that hydrofluorination of perchloroethylene on chrome-magnesium fluoride catalyst yielded mostly  $\text{ND}_2$ -containing isomers of tetrafluorochloroethane and trifluorodichloroethane. This provides an additional advantage of the one-reactor process implementation if the products of incomplete fluorination return to the synthesis. The thing is that hydrofluorination of 1,1,1,2-tetrafluorochloroethane occurs with endothermic effect thus decreasing total exothermic effect of perchloroethylene hydrofluorination; this enables us to reduce excess of hydrogen fluoride or to feed more perchloroethylene into the reactor during the technological process.

It was shown that content of pentafluorochloroethane in organic composition of the resulting product mixture was 20-60% by volume if fluorination of perchloroethylene (blended with incompletely fluorinated products) occurred at 360-440°C, contact time was 10-30 sec, HF: organic ( $\text{C}_2\text{F}_4$  + incompletely fluorinated products) mole ratio was (5-20): 1. Perchloroethylene conversion degree achieved 60-97%.

Pentafluorochloroethane formed in this synthesis process was separated from pentafluoroethane by water absorption. The resulting content of the main substance in the marketable product was more than 99.8%.

## **DEVELOPMENT OF TETRAFLUOROMETHANE SYNTHESIS FROM FLUOROCHLOROMETHANES**

*Y.G. Trukshin, A.N. Firsov, V.I. Shubin, V.M. Vishnyakov, S.G. Fedorova*  
*RSC "Applied Chemistry", 14 Dobrolubov ave, 197198, St. Petersburg, Russia*  
*JSC "Halogen", 614113, Perm NTF "Komkon", 14 Dobrolubov ave., 197198, St. Petersburg, Russia*

The industrial method of tetrafluoromethane production is based on carbon fluorination with gaseous fluorine.

However, it is possible to prepare tetrafluoromethane using less amount of expensive raw materials, namely difluorodichloromethane and hydrogen fluoride.

Gas-phase catalytic hydrofluorination of difluorodichloromethane was studied in a reactor with a fixed bed of chrome-magnesium fluoride catalyst. It was shown that the most favorable conditions of tetrafluoromethane synthesis are: temperature 450-500 °C, mole ratio HF: difluorodichloromethane (2-6): 1, exposure time of the components in the reaction area 10-20 sec. In this case the content of tetrafluoromethane in the reaction gas mixture was 77-85%, and conversion of difluorodichloromethane was virtually complete

### **STUDY OF HEXAFLUOROETHANE SYNTHESIS FROM FLUOROCHLOROETHANES**

*KG. Trukshin, V.M. Vishnyakov, S.G. Fedorova RSC "Applied Chemistry", , 14 Dobrolubov ave., 197198, St. Petersburg .Russia*

Most of hexafluoroethane manufacture methods are based on power-consuming processes (pyrolysis of CHF<sub>3</sub>, C<sub>2</sub>F<sub>4</sub>) or those using elemental fluorine (carbon combustion in fluorine, etc.). Application of these processes resulted in high prime cost of hexafluoroethane. However, some byproducts of pentafluoroethane industrial synthesis are ozone-depleting substances (pentafluorochloroethane, tetrafluorodichloroethane, trifluorotrichloroethane) that can be used as raw materials for hexafluoroethane manufacture. Moreover, this synthesis can use freon 113 available at other enterprises and now being phased-out.

The conducted studies have shown that hexafluoroethane is obtainable by gas-phase catalytic hydrofluorination of pentafluorochloroethane, tetrafluorodichloroethane, trifluorotrichloroethane or their blends in fixed or fluidized bed of chrome-magnesium fluoride catalyst under ambient or increased pressure. The best temperature range for the process was 530-580°C, and the best HF: organic mole ratio was (3-12): 1.

The content of pentafluorochloroethane in the reaction mixture was 35-50% by volume during hydrofluorination of pentafluorochloroethane, and 15-25% by volume during hydrofluorination of tetrafluorodichloroethane, trifluorotrichloroethane or blends of fluorochloroethanes. The main byproduct of the process was pentafluoroethane (0.1-1% by volume).

### **STUDY OF HEPTAFLUOROPROPANE SYNTHESIS FROM HEXAFLUOROPROPYLENE**

*Y.G. Trukshin, I.E. Mitina, V.G. Barabanov RSC "Applied Chemistry", 14 Dobrolubov ave., 197198, St. Petersburg. Russia*

Heptafluoropropane (CF<sub>3</sub>-CHF-CF<sub>3</sub>, Freon 227ca) is a powerful ozone-nondepleting fire extinguishing agent applicable for bulk fire extinguishing instead of halons (freons 13b1, 12b1). Heptafluoropropane is synthesized from hexafluoro-propylene:



This reaction proceeds both in gas and in liquid phase.

The liquid phase process requires expensive catalyst (based on Ta, Nb) and rather long components exposure time in the reaction area. That is why for industrial applications we propose to use gas-phase-catalyzed hydrofluorination of hexafluoropropylene.

Hydrofluorination of hexafluoropropylene was conducted in fixed bed of chrome-magnesium fluoride catalyst.

Laboratory investigations showed that the process efficiency reached maximum at 350-450°C, contact time 7-30 sec, mole ratio of the components HF: C<sub>3</sub>F<sub>6</sub>=(1-2): 1.

This conclusion was confirmed by the results of our pilot unit operation. Content of freon 227ca in the reaction gas (evaluated in organic product percentage) was 50-70%. Selectivity of freon 227ca manufacture process was 97-98%.

Rectification of the reaction mixture was used to prepare a tentative lot of the product with the main substance content 99.9% by volume.

## **DEVELOPMENT OF TECHNOLOGY OF HEPTAFLUOROPROPANE FROM BY-PRODUCTS OF FLUOROORGANICS MANUFACTURE**

*Y.G.Trukshin, A.N.Firsov, V.I. Shubin, V.F.Denisenkov, V.G.Gavrilov, I.E. Mitina JSC "Halogen", 614113, Perm*

*RSC "Applied Chemistry", 14 Dobrolubovave., 197198, St. Petersburg, Russia NTF "Komkon", 14 Dobrolubov ave., 197198, St. Petersburg Russia*

Still residues formed in tetrafluoroethylene manufacture contain a number of high-fluorinated substances (freons 318c, 124, 226, etc.).

Some of these products are of independent interest (e.g., freon 318C), other can be used as raw materials for synthesis of new fluororganic substances. Freon 124 can be separated from the still products and used at pentafluoroethane synthesis (ozone-non-depleting extinguishing agent). Heptafluoropropane ( $\text{CHF}_2\text{-CF}_2\text{-CF}_3$ , freon 227ca) is also a powerful ozone-non-depleting extinguishing agent.

This study was intended to develop a method of freon 227ca manufacture based on hexafluorochloropropane from the still residue; method of hexafluoropropane extraction from still residue was implemented at JSC "Halogen".

Gas-phase catalytic hydrofluorination of freon 226 was applied for freon 227ca synthesis. Chrome-magnesium fluoride was used as the process catalyst.

It was shown that content of freon 227ca in the reaction mixture was 45-50% when the reaction temperature was 450-510°C, mole ratio HF:  $\text{C}_2\text{F}_6\text{HCl}$  was (2-4): 1 and the exposure time of the components in the reaction area was 5-15 sec. The process selectivity evaluated from freon 227ca was 80-87%. Rectification of the reaction mixture was used to isolate the target product with the main substance content more than 95% [vol.].

## **DROP-IN CFC12 ALTERNATIVE FOR REFRIGERATION EQUIPMENT**

*V.G. Barabanov, V.S. Zotikov, V.A. Saraev, A.D. Esenina, \* E.A. Bolshakov, \*V.I. Samoilenko*

*Russian Scientific Centre "Applied Chemistry" (RSC "ACH"), 14 Dobrolubov ave., St. Petersburg, 197198, Russia \*Centre of refrigeration equipment (CRE), 27 Kurskaya str., St. Petersburg, 192007, Russia.*

Halting of the production of freon 12 in developed countries complying with the Montreal Protocol made it necessary to look for alternatives fit for maintenance of equipment operated on this refrigerant. R134a is impracticable for this purpose because it is incompatible with mineral oil and requires some modifications of the refrigeration machine construction. RSC "Applied

Chemistry" (in cooperation with a number of organizations that specialize in refrigeration machines servicing) develops substituents based on HCFCs, HFCs and hydrocarbons, particularly

on R22, R134a, R142b, R21, R600 and others commercially produced at Russia. The refrigerant blends based on R22 much like to R12 are non-combustible, non-toxic and compatible with mineral oil X<1)12-16 used in operating equipment.

Contrary to the refrigerant blends manufactured abroad, e.g., R401a and R409a these newly developed compositions do not require to charge alkylbenzene oil instead of mineral oil or to modify the refrigeration machine construction. This combined computer and experimental study resulted in a new refrigerant blend arbitrarily called CIOM with performance properties close to those of R12. The report shows both physico-chemical and thermophysical properties of CIOM and the results of long-term operation of household and commercial refrigerators charged with this blend.

The results of this study and of CIOM application in operating equipment obtained by specialists of RSC "Applied Chemistry", CRE, International Academy of Refrigeration and Food Technologies, JSC "Astor", JSC "Halogen" confirm that CIOM is a promising candidate as a drop-in R12 substituent for equipment now operating on R12 and mineral oil.

## **THE SELECTION OF THE TECHNOLOGICAL SCHEME OF THE REACTION ASSEMBLY FOR THE PROCESS OF 1,1,1,2-TETRAFLUOROETHANE SYNTHESIS**

*A..V. Dmitriev, A.S. Kuznetsov, I.G. Trukshin, V.G. Barabanov  
RSC "Applied Chemistry", 14 Dobrolubov ave., 197198, St-Petersburg, Russia*

The mathematical model of the process of 1,1,1,2-tetrafluoroethane synthesis (freon 134a) in the adiabatic reactor with the fixed bed of the catalyst, which take into account the transfer of the mass, impulse and energy of the continuous phase on the reactor, the transfer of the heat on the catalyst, the exchange of the mass, impulse and energy between the continuous phase and the catalyst, the difference of the temperature between the continuous phase and the catalyst and the kinetics of the chemical reactions was developed.

The process of freon 134a synthesis may be represented in the form of two main stages:

1. hydrofluorination of trichloroethene to 1,1,1-trifluorochloroethane (freon 133 a)



2. hydrofluorination of 1,1,1-trifluorochloroethane to 1, 1, 1,2-tetrafluoroethane

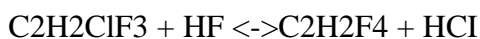

Owing to the reversibility of the second stage of the process it is necessary to organize the reaction assembly so that the removal of hydrogen chloride from the reaction zone took place and promoted the creation of the optimum reaction conditions and the achievement of the maximum yield of the main product (freon 134a). The decrease of hydrogen chloride concentration in the reaction zone may be provided with the carrying out of the process in two-reactor scheme. The analysis of the reaction assembly and the calculation of its optimum scheme were fulfilled on the base of received mathematical model.

Among four probably versions of the process organization in two reactors the next version is most effective: hydrogen fluoride, trichloroethene and part of recycle (to the maintenance of the temperature conditions) are supplied in first reaction zone, recycle (mainly freon 133a and

hydrogen fluoride) is supplied in second reaction zone, streams from the reaction zones are united and turned on the separation of hydrogen chloride, low boiling products and main products whereas high boiling products are directed to the synthesis assembly as recycle; temperature in the first reaction zone 160 C, in the second one 400°C (at the total flow of freon 134a as an efficiency index).

## **HFC MIXED REFRIGERANT CMI AS AN OZONE-SAFE AND EFFECTIVE CFC-12 SUBSTITUTE**

*Ph.D., A. I.Lunin, Ph.D O.N.Podchemiaev, Ph.D. B.V.Yudin Moscow Power Engineering Institute (MPEI)*

It is well known that the thermodynamic efficiency of a refrigeration cycle on HFC-134a is perceptibly lower than that with traditional CFC-12 refrigerant. The analysis of the experience with transition to R134a shows that even significant changes in the system design and use of high efficient new compressors allow to decrease the power consumption of new systems only by 3% to 5% compared to the existing R12 systems. At the same time these improvements resulted in a penalty in terms of increased system cost (new materials, lubricants, desiccants etc.). Moreover, installation of new assembly lines or redesign of the existing ones require significant investments which most of Russian manufacturers can not afford.

The refrigerant CMI was developed especially as a direct replacement for R12 to overcome the noted difficulties. It is a non-flammable three-component mixture having zero ozone depletion potential. The refrigerant is compatible with the existing mineral oils and equipment and can be used as a retrofit or in production of direct expansion refrigeration systems.

One of the components of CMI is 1,1,2,2-tetra-fluoroethane (R134). This substance can be produced using chemical waste which is accumulated today in huge amounts. It allows to get the double ecological effect resulted from CMI implementation.

The initial tests of CMI were conducted in a research laboratory of MPEI and then in several technical laboratories of household refrigerators manufacturers. The new refrigerant has shown performance characteristics that are very similar to those of R12. In some systems, such as refrigerator MIR-101, which has a food compartment evaporator, the use of zeotropic refrigerant CMI led to decrease in power consumption by 10% compared to R12 and by 30% compared to R134a. These results are achieved without any modification of the existing equipment. It is obvious that further performance improvement in systems with two evaporation temperature levels is possible by utilization of temperature glide which is a benefit of new zeotropic refrigerant.

## **THE PERFLUORINATED BRANCHED $\alpha$ -KETORADICALS**

*B.L. Tumanskii, K.N. Shaposhnikova, N.N. Bubnov, S.P. Solodovnikov, E.A. Avetisyan and S. R. Sterlin. Institute of Organoelement Compounds, 117813 Moscow, Russia.*

The synthetic routes leading to the formation of fluorinated ( $\alpha$ -ketoradicals  $RfC(O)CRF'RF_2$  (I) and anion-radicals - the derivatives of fluorinated ( $\alpha$ -diketones  $RfC(O)C(O)RF'$  ( $RF'$ =fluoroalkyl, fluoro-acyl) (II) are considered. I - II can be obtained

- by photolysis of  $\alpha$ -fluorosulfatoperfluoroketones;
- by transformation of  $CFOSO_2F$ -group into  $CO$ -group in  $P$ -fluorosulfatoperfluoroalkyl radicals

under the action of F<sup>-</sup> ;

c) by addition of radical particles to fluorinated (-polyketones;

d) by photoreduction of (-polyketones in the presence of hydrocarbons;

e) by one-electron reduction of fluorinated (-polyketones.

The synthesized I-II do not contain moieties other than CO-group which are capable to come into conjugation with the paramagnetic centre. That is why I - II are considered to be the convenient objects for investigation of reactivity of radicals and anion-radicals, where the unpaired electron is delocalized in heteroallylic triade 'C-C=O.

The ability of I to enter the hydrogen abstraction reactions and dimerization reactions are mostly determined by steric factors and unpaired electron density on O-atom. The kinetic and thermodynamic parameters of these reactions, the influence of solvents upon these parameters and the calculation data of the unpaired electron density distribution in the heteroallylic triade are given.

## APPLICATION OF P(NEt<sub>2</sub>)<sub>3</sub> FOR FLUOROORGANIC SYNTHESIS

V.V.Bardin, L.S. Pressman, V.F.Chertkov, G.G.Furin  
Institute of Organic Chemistry, 630090, Novosibirsk, Russia

Tris(dialkylamino)phosphines P(Alk<sub>2</sub>)<sub>3</sub> are readily available. They have a wide synthetic application which display by examples given below.

Carbon - carbon bond formation:

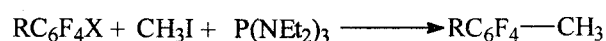
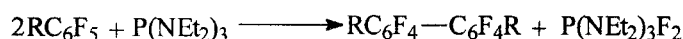

Образование связи углерод - элемент:

Carbon - element bond formation:

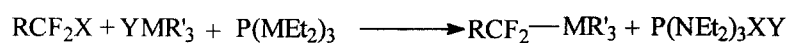
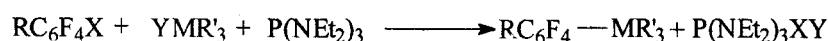

Образование связи углерод- водород (восстановление):

Carbon - hydrogen bond formation (reduction):



Дегалогенирование:

Dehalogenation:

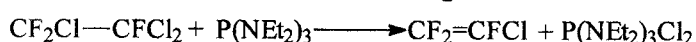

All reactions proceed easily at 20-40 C hydrocarbons: (hexane, light petroleum, benzene), ethers and esters (diethylether, diglyme, ethyl acetate), nitriles (acetonitrile, benzonitrile) or dichloromethane, which allow to optimize the reaction conditions for required product. Salts P(Alk<sub>2</sub>)<sub>3</sub>XY simply separated from the products and can be regenerated into P(Alk<sub>2</sub>)<sub>3</sub> by the methods.

## **HYDROFLUOROCARBONS SYNTHESIS ON BASE OF FLUORINATED OLEFINES CATALYTIC HYDROGENATION**

*N.V.Zakharova, M.D.Novikova, A.N.Golubev,  
V.Yu.Zakharov*

*Open Joint Stock Company "Konstantinov Kirovo-Chepetsky Khimichesky Kombinat" ,  
Kirovskaya Obi., Kirovo-Chepetsk, Russia*

Feasibility of gas phase catalytic hydrogenation of tetrafluoroethylene, hexafluoropropylene, difluoroethylene, perfluorobutene over various Al<sub>2</sub>O<sub>3</sub> supported catalysts (Pd, Ni, Ru, Fe, Co), with ozone-safe refrigerants obtaining as a result, has been investigated under laboratory conditions.

The catalyst Pd/AL<sub>2</sub>O<sub>3</sub> is shown to have the highest activity and selectivity. The synthesis proceeds gently and is characterized by high yield of hydrogen selective addition compounds: yield of Khladon 134, Khladon 236, Khladon 338 has exceeded 99%.

## **CRYOPOLYMERIZATION OF TETRAFLUOROETHYLENE IN POROUS SORBENTS**

*I.M.Barkalov, I.P.Kim, D.P.Kiryukhin, P.S.Mozhaev, G.A.Kichigina, I.A.Juranov and  
V.V.Barelko Institute of Chemical Physics in Chernogolovka, Russian Academy of Sciences,  
Moscow Region, 142432 Russia.*

Tetrafluoroethylene and other monomers are well sorbed in porous sorbents. At the fast cooling of such system up to 77 K. the sorbed monomer holds back in porous transfers in amorphous metastable phase, but no formation of own crystalline phase. Such amorphous microaggregates have rise (near on order) reaction ability to formation of polymer comprising with crystalline phase of monomers in the same conditions of experiments.

The amounts of such microaggregates can be definite by the calorimetric experiments. We have carried out the experimental investigations on formation noncrystalline aggregates of tetrafluoroethylene in various porous sorbents. It were used in the experiments the following sorbents: macroporous silica Fibres, silicagel, porous carbon sorbent and activated carbon. Some amount (20-100%) of tetrafluoroethylene in various porous sorbents was transferred into nonequilibrium amorphous phase. The radiation polymerization of this amorphous phase in porous proceeds more effectively than in usual phase (liquid or crystal). There are autooscillation and heat explosive regime.

## **REACTIVITY OF FLUOROCARBON RADICALS**

*S.R. Allayarov, I.M. Barkalov  
Institute of Chemical Physics in Chernogolovka, Russian Academy of Sciences , Chernogolovka,  
142432, Russian Federation. Fax:(095)2655714*

The average stability time of fluoroorganic radical, which are intermediates in complex chemical reactions is, as a rule, essentially higher than that of their hydrocarbon analogues. Discovery of the existence of a series of radicals incapable of mutual recombination in liquid is the most clear example confirming the correctness of that tendency. Apparently, these three-valence carbon stable intermediates are the extreme point of the wide life time spectrum of the fluoroorganic radicals. At present, the kinetic and mechanisms of a series of reactions are limited by LR

formation have been studied by us. The main tendency of our investigations including the nonpublished data, has been considered.

In this report the following principle questions are discussed.

- the mechanism of LR formation (radiolysis, UV-irradiation, halogenation);
- the LR, "reviving" ways when acted upon by light heat and chemical reagents;
- the model of radical (co)polymerisation considering the LR formation;
- the specific features of the radiolysis destruction of fluoroorganic compounds (FOC), the increase of the fluoropolymer radiation stability by use of LR formation.

In this work, the following principle FOCs have been used.: unsaturated FOCs (tetrafluoroethylene, trifluorochloroethylene, vinylfluoride, vinylidene-fluoride, hexafluoropropylene (GFP), dimer of GFP, derivatives of the GFP dimer, trimer of GFP, derivative of the GFP trimer, perfluoroisobutylene, perfluoroaliphatic compounds, fluoroaromatic compounds, linear perfluoroalkanes (perfluorohexane, per-fluorooctane, perfluoroundecane, perfluorohexadecane), nitrogen- and oxygen-containing FOCs, as fluoropolymers.

## **INTERACTION OF HYPOFLUORITE WITH FLUOROCHLOROMETHANE AND TETRAFLUROETHYLENE IN THE PRESENCE OF OXYGEN II. ANALYTICAL MENAGEMENT'S STUDY**

*Avigeja N. Ivanova, Ann A.Karnaukh, Igor M.Barkalov Institute of Chemical Physics in Chernogolovka, Russian Academy of Sciences, Chernogolovka, 142432 RUSSIA*

Developed by us method of computer analysis a network of reactions (CARN) applying for the study discovered earlier nonmonotonic influence of oxygen on kinetic regimes and product composition of gas-phase branched-chain reactions of some halomethanes (RH) fluorination by hypofluorite (CF<sub>3</sub>OF).

As analyzed arc considered two schemes. Base one of they form a scheme of interaction between hypofluorite and fluorochloromethane, taking nonlinear interactions of leading and peroxide radicals into account and complemented by ephoxidizing reaction of the intermediate tetrafluoroethylene with peroxide radicals, which is a consource of active centers due to the decomposition chemical activated oxides of the tetrafluoroethylene. Other scheme on the contrary based on extended models of interaction hypofluorite with tetrafluoroethylene in the presence of oxygen, complemented by interactions between radicals with the general formula RO and halomethane (RH). Analytical expression of condition of autoacceleration is got in the manner of inequalities of Semenov's type ( $p = A - B > 0$ , where A and B is multinomial, composed of contributions from critical and noncritical fragments of scheme, accordingly, and different image linking constants rates of reaction with experimental system parameters, including with concentrations of initial reagents, as well as intermediates, radicals and oxygen. Last has allowed, having presented inequality in the manner of multinomial on concentrations of oxygen, analyze a nature of influence of separate contributions on change A and B, and, consequently, on the acceleration or inhibition of process in its begin, or on the measure of consumption of oxygen.

Computer analysis of formulas in combination with kinetic calculations allow to explain a nature of sharp change degrees and sign of influence of oxygen under small changing its concentrations,

in particular, define an area an intensification of process by small additives of oxygen and corresponding this increasing a share of products of oxigenative conversion a halo-methane, which precedes to the fluorination itself and rarefied with him on a time.

## PLASMACHEMICAL DESTRUCTION OF HALOGENATED WASTE MATERIALS

*Yu.P.Malkov.A.A.Davidjan, M.A.Rotinian, V.I.Karpumn, V.N.Semjenov*

*RSC"Applied Chemistry", 14 Dobrolubov ave., 197198, St. Petersburg, Russia*

KEYWORDS: TOXIC WASTE DISPOSAL, HALOGENATED WASTE MATERIAL, PLASMA PYROLYSIS.

One of the most promising method for destruction of halogenated waste is plasma pyrolysis, which has a number of advantages as compared with traditional technologies:

- a) high temperatures, preventing the formation of any complicated toxic byproducts (such as dioxins, chloro- and fluorophosgenes etc.);
- b) high concentration of energy permitting the process to be carried in small-scale technological equipment and even in mobile unit;
- c) possibility of using different gases and their compounds (air, nitrogen, hydrogen, water vapor etc.) as a working gas, optimum from the viewpoint of safety and efficiency of the process.

We offer plasmachemical option for destroying gaseous and liquid halogenated organic waste (including those having a great viscosity). A diagrammatic view of this method is presented on the sketch.

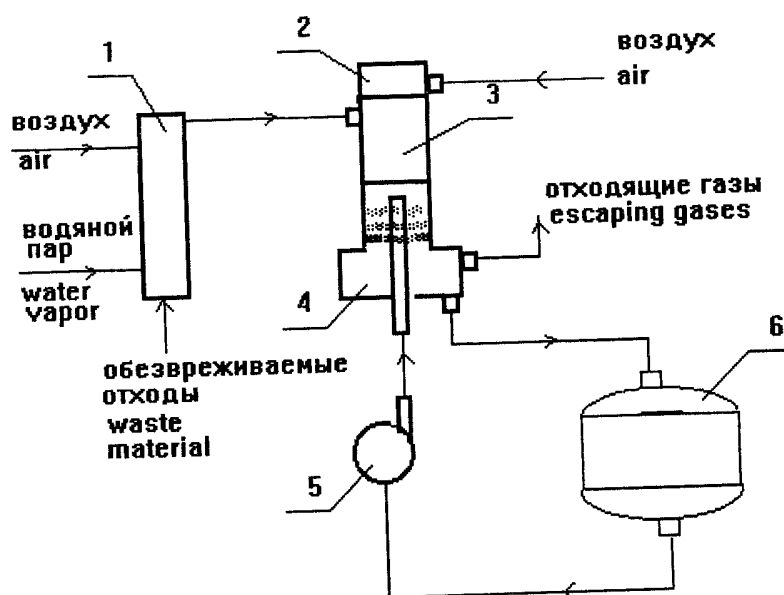

The waste material is preheated to the temperature, not exceeding the temperature of the thermal destruction, then it is evaporated and mixed with heated air in the mixture preparation unit 1. The prepared air-vapour mixture is injected into the air plasma flame, flowing from plasma generator 2 to the reactor 3, where the plasma pyrolysis occurs at a temperature of at least 1500°C, dwelling period between 2 and 10 ms and in a surplus quantity of oxygen. If the hydrogen content of the waste to be destroyed is low, it is advisable to introduce also a water vapour into the plasma for binding the halogens with formation of hydrogen halogens. When the reaction products emerge from the reactor they are quenched and neutralized simultaneously with water alkaline solution, which is supplied using the pump 5 from reservoir 6 to quenching-neutralizing unit 4, where it is atomized with spray nozzles. The escaping gases containing N<sub>2</sub>, O<sub>2</sub>, CO, CO<sub>2</sub>

and water vapour, are released to the atmosphere. In the process the concentration of alkali (NaOH) in the quenching - neutralizing agent decreases and it is added up to initial concentration and after the removal of salt precipitate (NaCl, NaF, Na<sub>2</sub>CO<sub>3</sub>), the solution is used again. Escaping gases analysis equipment includes gas chromatograph "Tracer 570 with thermal conductivity detector coupled to electron capture detector or to mass-spectrometer Q-156. The mass-spectrometer scans up to 6 specific masses corresponding to those ions indicates the presence of toxic compounds. Identification of mixture's components is effected with using of mass spectra's library including compounds, which presence could be foreseen according to the results of the chemical equilibrium computation. The method described above was used for destroying halogenated organic chemicals of various compositions. Among them were R133a (CF<sub>3</sub>CClH<sub>2</sub>), R12 (CF<sub>2</sub>Cl<sub>2</sub>), R14 (CF<sub>4</sub>), galon 1301 (CF<sub>3</sub>Br), and pentachlorobiphenyl (PCB).

### **THE APPLICATION OF DERIVATIVES OF PERFLUORINATED CARBON ACIDS AT THE HORSE FARMS TO PROTECT THE WOOD FROM MICROFUNGI INFLUENCE**

*Ya. V.Zachinyaev, A. V.Zachinyaeva, I.I.Solomennikova\**

*State Technological Institute, St.Petersburg (Technical University), 26, Moskovsky av., St. Petersburg, 198013, Russia*

*\*Latvian Academy of Sciences, 19, Turgeneva str., Riga, LV-1524, Latvia*

The problem of lowering of biological destruction of organic compounds is acquiring main importance in agricultural building, in which various natural and synthetic materials are applied in considerable amounts. Very strong alterations occur with the wood constructions and wares at the horse farms. For example, wood floors in 1-1,5 years are effaced already, are rotted and out of order as well, in spite of use the wood of valuable coniferous breeds for their production. It is necessary to notice, that in conditions of prolonged damping of floors develop the domestic fungi: Serpula, Coniophora, Coriolus etc. (Different species of these genesis). Taking these data about destructive processes of wood materials at the horse farms into account we worked out new lasting wood floors. In order to improve the working properties of floors, liquid non-toxic compounds ( functional derivatives of perfluorinated carbon acids:

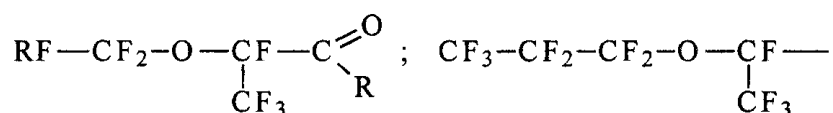

калы.

**R= different radicals.**

The wood materials were impregnated with such substances throughout. As a result the new wood material was carried out, possessing complex of valuable properties, which surpass the properties of the initial material. So, processed wood demonstrates biological and chemical stability as well as incombustibility simultaneously.

As a result of use of such modified wood the durability of floors at the horse farms increases considerably. High level economic effect is arrived despite of primary technological expenditures.

These adduced data on prevention of destruction of the wood at the horse farms may be used at the natural testing areas for prevention of its destruction by microfungi.

## **KINETICS OF GASEOUS FLUORINATION OF 1,1,1,2-TETRAFLUOROETHANE WITH ELEMENTAL FLUORINE**

*D.S. Pashkevich, D.A. Muhortov, E.A. Podpalkina, V.G. Barabanov Russian Scientific Center "Applied Chemistry", 14, Dobrolubov ave., St. Petersburg, Russia. Phone: (812) 536-93-67*

Currently no data are available in literature neither on kinetic characteristics of gaseous fluorination of 1,1,1,2-tetrafluoroethane with elemental fluorine nor on activation energy of the reaction. Only the rate constant at room temperature is known for this process.

We have undertaken an experimental study intended to determine the type of kinetic equation and temperature sensitivity of gaseous fluorination of 1,1,1,2-tetrafluoroethane to give pentafluoroethane.

The regime of the experiments was stationary isothermal at 105-148°C in absence of any inert diluent, fluorine was 4-10% by volume.

The experimental results have shown that the reaction was autocatalytic, order of autocatalysis was 1-2. The reaction order by fluorine was fractional: 0,5-1. Activation energy of reaction was shown to be 50 kJ/mole .

The observed kinetic characteristics were treated on basis of the chain reaction theory.

## **PERFLUORINATED PARAFFINS AND ETHERS PRODUCTION BY FLUORINATION OF FLUORINE-CONTAINING OLEFINS, PARAFFINS AND ETHERS**

*T.A. Bispin, D.D. Moldavsky, G.G. Furin\**  
*Russian Academy of Science, Institute of Organic Chemistry, Novosibirsk 9 Lavrentyeva ave., Novosibirsk, 630090, Russia \**  
*RSC "Applied Chemistry" 14 Dobrolubov ave., St.Petersburg, 197198, Russia*

As we believe, a perspective method for perfluoroorganic compounds production is fluorination by elementary fluorine of fluoro-containing predecessors.

Fluorination of perfluorinated olefins C<sub>2</sub>-C<sub>12</sub>, polyfluorinated paraffins C<sub>1</sub>-C<sub>5</sub> containing 1-2 atoms of hydrogen and perfluoroalkene alkoxydes has been investigated.

Fluorination was carried out by dosing of 100% fluorine into a reactor of nickel of 150 ml volume supplied with regulated cooling and heating (from minus 35°C to plus 150°C) and filled with the substratum under investigation. The rate of fluorine feeding was settled so that increase in temperature in the reactor was not more than 1 °C.

Longer chain olefins and paraffins are more difficult to fluorinate. The preferred temperature range for fluorination is -35°C to +120 °C. As chain length increases the yield of desire products decreases (from 99 to 65%).

During fluorination of perfluoroalken- and monohydro perfluoroalkyl-alkoxydes the yield of perfluorinated ethers decreases while alkyl chain length increases (from 95% for methoxy- to 35% for n-butoxy derivatives)

The results obtained have been the base for the industrial-experimental technology of perfluoropropane and perfluoropropyl methyl ether production.

## **NON-CATALYTIC METHOD OF R-141b, R-142b, R-143a MANUFACTURE**

*P. Orlov, V. B. Shchavelev, D. N. Korolkov*  
*Russian Scientific Center "Applied Chemistry", 14 Dobrolubov ave., 197198, St.Petersburg, Russia*

Full-scale industrial production of 1-fluoro- 1, 1-dichloroethane (R-141 b), 1, 1-difluoro-1-chloroethane (R-142b), 1, 1, 1-trichloroethane (R-143a) make use of catalytic fluorination of methylchloroform or vinylidene chloride with hydrogen fluoride. The ordinary catalyst is lead tetrachloride.

A non-catalytic method of R-141b manufacture starting from vinylidene chloride or methylchloroform is well known. No data are available on this method application to R-142b and R-143a manufacture. The main impediment to the non-catalytic method application was strong tarring of the raw material (organochloric substances) and low yield of R-142b and R-143a.

We have developed a non-catalytic liquid-phase method of R-141b, R-142b, R-143a synthesis; these three products are present in the synthesis gases simultaneously. The success was due to application of a fundamentally new method, using a reactor combined with a rectification column. The reaction products after condensation were separated from hydrogen fluoride by stratification. HF then returned into the reactor and organic medium, cleaned from hydrogen fluoride and hydrogen chloride, was the separated oy rectification.

On the basis of supposed mechanism of vinylidene chloride interaction with hydrogen fluoride we applied the intenary method to deduce kinetic equations and to estimate the kinetic constants of the process. The assumed mechanism has been confirmed by reasonable conformity of the calculated results with those obtained at our pilot plant.

The process was developed at the continuously operated pilot plant, raw material being vinylidene chloride. It was shown that organic products tarring may be much decreased as to compare with the results of the catalytic method. The content of the synthesis products was shown to be easily regulated by change of the technological parameters. In case of intentional synthesis of R-141b this product content was 93-96% by mass. If the process was carried out in the reactor without circulation of organic, at 80-120 °C under pressure up to 8 kg/cm<sup>2</sup>, the finish content of R-142b was 45% by mass, R-143a content was 20% by mass.

The present non-catalytic process was offered to update now existing catalytic process of R-141b, R-142b, R-143a manufacture at the given ratio.

## **IN SEARCH OF NON-OZONE-DEPLETING SOLVENTS: STUDY OF RATES AND MECHANISMS OF OILS AND LUBRICANTS DISSOLVING PROCESS**

*A.P.Orlov, V. V.Amfiteatrov. L.S.Vestfall, D.N.Korolkov*

*Russian Scientific Center "Applied Chemistry", 197198, 14 Dobrolubov ave.,St. Petersburg, Russia*

The search for non-ozone-depleting substituents for such universal solvent as R-113 made it necessary to compare rates of different contaminants dissolving in various alternatives. For this purpose we have applied the method of "vibrating needle" to study kinetics of geterogenous dissolving of organofluoric oligomer lubricants (3F, 4F, 4LF) in R-113, R-141b, R-122 under continuous control of the solution concentration at the lubricant-solution boundary. We were recording both frequency and attenuation of free rotational vibrations of a needle (that was a cylinder of very small diameter) attached to a pendulum instrument. The side surface of the needle was covered with a lubricant. The solution concentration has effect on the solution viscosity and, therefore, on the parameters of the pendulum vibrations. Given the vibrogram one was able to determine the time-dependence of the vibrations attenuation and to estimate, starting from this dependence:

the maximum possible rate of the species escaping from the lubricant surface and time necessary to achieve this rate;

time it takes the rate of the product dissolving and the rate of the solute diffusion to become equal;

rate constants both for dissolving and diffusion process.

Time-dependence of the solute concentration at the "lubricant-solution" boundary was found to have the same character for all studied lubricants and solvents. It was therefore concluded that the process proceeded in three stages, one after another. At the first stage the solute was activated due to the solvent penetration in it; this process has an inductive period followed by acceleration. The rate of the second stage is relatively constant, the rate of dissolving being higher than that of the lubricant diffusion in the solvent. At the third stage the lubricant diffusion was found to be the rate-controlling process.

The developed method was applied to show that the rate of the lubricant (e.g., 3F) dissolving increased and the induction period decreased in the row of solvents: R-113 -> R-141b -> R-122.

## **CONDUCTOMETRIC METHOD OF MINERAL ACIDS CONTROL IN TECHNOLOGICAL FLOWS AT FLUOROCARBONS MANUFACTURE**

*B. S. Besprosvanniy, A.P.Orlov, V.B.Shchavelev, D.N.Korolkov*

*Russian Scientific Center "Applied Chemistry", 197198, 14 Dobrolubov ave., St. Petersburg, Russia*

Industrial production methods of khladons (chlorofluorohydrocarbons (CFCs) and fluoro-hydrocarbons (HFCs) are based on chlorine replacement with fluorine in the course of some organic substances interaction with hydrogen fluoride in gas or in liquid. To obtain a marketable product it is necessary to clean khladons from mineral acids (hydrogen chloride and hydrogen fluoride). So khladons cleaning is closely allied to mineral acids continuous control in technological flows of full-scale industrial units.

High dielectric properties of pure khladons (specific electric conductivity  $\kappa_0 < 10^{-9}$  cv.cv<sup>-1</sup>, dielectric constant ( $\epsilon = 2.0-2.5$ ) are directly related to very low degree of the mineral acids dissociation (ionization). So the idea to apply the conductometric method stems from assumption that water traces are of crucial importance in mineral acids ionization in khladons and in the mechanism of electric conductivity. At the same time the dissociation degree of water decreases due to very low water concentration (it manifests itself in limited hydrate shells of ions); the concentration functions do not correspond to the physicochemical laws of electrolytes.

The method applicability to the impurities' content control and khladons purity estimation was tested on-line in R-141b cleaning process to control mineral acids in the flow, both before and after cleaning. Electric conductivity of R-141b was measured upstream and downstream from the adsorption cleaning unit with the help of special sensors, not disrupting the liquid flow and standard P-3050 bridge. Electric conductivity was shown to fell 30-100 times depending on the initial product purity (electric conductivity) and the resulting conductivity at the adsorber's exit was nearly constant:  $\kappa_0 < 10^{-9}$  cv.cv<sup>-1</sup>, It means that the conductometric method permits us to control the process of freons cleaning from mineral acids.

The present study has shown, that electroconductivity control of the finish product maybe applied to standardize the marketable product and electroconductivity may be used as a standard characteristics of the product.

The applicability of the conductometric control method was tested both in technological flows and in marketable product at R-141b continuous manufacture.

## **PROCESS OF PENTAFLUOROETHANE AND HEXAFLUOROETHANE PREPARATION BY GASEOUS FLUORINATION OF 1,1,1,2-TETRAFLUOROETHANE WITH ELEMENTAL FLUORINE**

*D.S. Pashkevich, D.A. Muhortov, Yu.I. Alekseev, G.I. Rileev*

*Russian Scientific Center "Applied Chemistry", 14,  
Dobrolubov ave., St. Petersburg, Russia. Phone: (812) 536-  
93-67*

Pentafluoroethane is an ODS alternative and according to the expert estimation the total demand for this substance may achieve 20 000 MT by year 2000. However, currently no technology is available pentafluoroethane industrial manufacture. It was proposed to produce pentafluoroethane and hexafluoroethane by gaseous fluorination of 1,1,1,2-tetrafluoroethane, 1,1,1,2-tetrafluoroethane being manufactured on an industrial scale.

Pentafluoroethane synthesis regimes were estimated basing on preliminary obtained kinetic data on fluorination of 1,1,1,2-tetrafluoroethane. The calculation has shown that it is very difficult to make an industrial reactor, were the synthesis take place in stationary regime. It was recommended to produce pentafluoroethane and hexafluoroethane in the regime of selfspreading stationary heat wave.

Gaseous fluorination of 1,1,1,2-tetrafluoroethane and pentafluoroethane with elemental fluorine was studied and was shown that it is possible to produce pentafluoroethane and hexafluoroethane under wave regime conditions without fluoromethane formation. On the base of this results the industrial reactor for pentafluoroethane and hexafluoroethane preparation was developed.

## **ODS PHASEOUT IN NON-INSULATING FOAMS MANUFACTURE**

*A.P. Orlov, V.B. Shchavelev, D.N. Korolkov*

*Russian Scientific Center "Applied Chemistry", 14 Dobrolubov ave., 197198, St. Petersburg,  
Russia*

Impressive success has been achieved in ODS consumption reduction in the sector of noninsulating foams manufacture due to development of new water-based formulations for polyurethane foams (PUF).

It resulted in total phaseout of R-113 both in furniture and in PUF blocks manufacture. Besides of that the similar foaming agent has been successfully introduced in semirigid PUF used in footwear manufacture. However, it was a matter of some difficulties to phaseout ODS in integral polyurethane foams (IPUF) manufacture for automobile construction industry.

The choice of the foaming agent for IPUF manufacture is influenced by the fact that foaming velocity growth has small effect on the core density, but a large one on the density and thickness of the surface film. That is why in IPUF manufacture they prefer to apply forming agents able to condense in restricted molds. During the foam formation process the foaming agent condenses on the cool surface of the mold and PUF thickens to give a monolith film.

New technologies intended to decrease ODS usage in non-insulating IPUF and polyethylene foams (PEF) manufacture are based on new foaming agents: water-based, CO<sub>2</sub> adding, fluorocontaining substances and hydrocarbons.

CFC-11 alternatives in IPUF manufacture are R-141b and isopentane. CFC-12 alternatives in PEF manufacture are R-134a and butane. CFC-11/CFC-12 blend is substituted by R-22/R-142 blend or by liquid CO<sub>2</sub>/butane blend.

Depending on the specific enterprise conditions the change-over process may proceed in 1 or 2 steps. The 2-step process implies change-over to HCFC foaming agents (R-141b,-142,-22) at the first step, and then change-over to non-ozone-depleting (NOD) substances (R-134a, hydrocarbons, liquid 002) at the second step. The 1-step process means direct implementation of technologies based on NOD foaming agents.

Total ODS phaseout in non-insulating foams manufacture is planned by the year 2000.

### **ODS PHASEOUT IN SOLVENTS SECTOR**

*A.P.Orlov, V.B.Shchavelev, N.B.Kopeikina, D.N.Korolkov*

*Russian Scientific Center Applied Chemistry", 197198, 14 Dobrolubov ave., St. Petersburg, Russia*

Ozone-depleting substances (ODS) (R-113 and methylchloroform) usage in cleaning is relatively small in Russia; in 1995 it was about 7% of total ODS usage (carbon tetrachloride not included). We have now several alternate cleaning processes and solvents to be applied instead of R-113. Their choice is governed by the purity (quality) of washing, best economy and technological parameters, environment and health protection, production safety. By now no ideal R-113 alternative was found to match all the properties of R-113. Some alternate cleaning procedures make use of water or semi-water washing; other alternate solvents are aliphatic hydrocarbons, fluorocarbons, perfluorocarbons, chlorine-containing solvents.

In 1993-1996 ODS consumption in the solvents sector decreased due to two reasons: firstly, due to the total production decline in Russia; secondly, due to alternative technologies implementation. The main R-113 consumers are: refrigeration compressors manufacturers, precise instruments manufacturers, state defense, rockets, missiles and spacecraft manufacture. The total strategy of ODS phaseout in Russia is claimed in the Russian Government Decree N 256 from 24.05.1995. The strategy implies creation of R-141b and R-122 manufacture. Step-by-step ODS phaseout in cleaning solvents sector must be finished by the year 2000. Depending on the specific enterprise conditions the R-113 phaseout process may proceed in 1 or 2 steps. The 2-step process implies change-over to transient solvents, those are HCFCs (R-141b, -122) at the first step, and then change-over to the long-term alternatives, those are: hydrocarbons, water solutions, liquid or solid 002 at the second step. The 1-step process means direct implementation of technologies based on long-term alternatives (NODS).

### **INVESTIGATION OF CHARACTERISTICS OF THERMODYNAMIC CYCLES WITH REFRIGERANTS R134a, R152a, R600a AND THEIR BINARY MIXTURES**

*A.A. Alexandrov, A. V. Dobrokhotoy, E.E. Ustjuzhanm, V. V. Altmin, B.F. Reutov, I.A. Silaeva*

*Moscow Power Engineering Institute 111250, 14 Krasnokazarmennaja St., Moscow, Russia*

The results of theoretical modeling of the nonregenerative (basic) refrigerating cycle are presented for six ozonesafe refrigerants - R134a, R152a, R600a and the blends R134a/R152a, R134a/R600a and R152a/R600a. The condensation temperature was 328K for every cycle. The temperature in the evaporator was varied in the limits 238-268 K.

The computer code is using the Camahan-Starling-De Santis equation of state for thermodynamic properties of refrigerants. The fitting parameters of this equation of state are

determined by treating the experimental and reference data on P-V-T-N-properties. The whole and differential characteristics of the cycle are calculated. They include the mass and volume refrigerating effects ( $Q_m$  and  $Q_v$ ), the power input ( $N_m$  and  $N_v$ ), the coefficient of performance COP and the pressure ratio in the compressor. The differential characteristics  $dQ$ ,  $dN$  and  $dCOP$  are determined in the relation to these characteristics for the cycles used R12.

The analysis of the basic refrigerating cycle shows that the characteristics of the azeotropic mixture R152a/R600a ( $g_2=27-28\%$ ) and the quazi-azeotropic mixture R152a/R134a ( $g_2= 80\%$ ) are close to characteristics of the cycle with R12 and considerably higher than of the cycle with R134a.

## REGIOSELECTIVE SYNTHESIS OF MFLUOROHALOGENOBENZENES FROM TETRAFLUOROETHYLENE AND BUTADIENE

*N.V. Volchkov, M.B. Lipkind, O.M. Nefedov*

*Zelinsky Institute of Organic Chemistry, Russian Academy of Sciences Leninsky Prospect, 47, Moscow 117913*

A simple three-steps method for regioselective synthesis of 2,3- and 3,4-difluorohalogenobenzenes starting from tetrafluoroethylene and butadiene has been developed. The method consists in a constructing of 1,2,3- or 1,3,4-trihalogenated benzenoid structures via thermal cycloaddition of tetrafluoroethylene to butadiene leading to a six-member fluorinated carbocycles which are transformed to difluorohalogenobenzenes by combination steps of halogenation - dehydrohalo-genation.

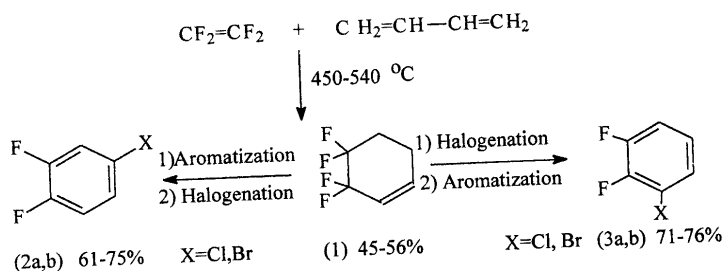

Using of this reactions scheme, the regioselective synthesis of 3,4-difluorochloro- or 3,4-difluorobromo-benzenes (2a,b) may be carried out via aromatization of 3,3,4,4-tetra fluorocyclohexene (1) by action of  $Al_2O_3$  at  $350^\circ C$  followed by halogenation of 1,2-difluorobenzene. In this case 1,3,4-trihalogenated structure of resulting benzenes is determined by dominant para-directing effect of an aromatic fluorine in the reaction of electrophilic substitutions.

On the contrary, when the halogenation step is preceding to aromatization step, the regioselective synthesis of 2,3-difluorochloro- or 2,3-difluoro-bromobenzenes (3a,b) may be also easily carried out via halogenation of tetrafluorocyclohexene (1) followed by aromatization of 1,2-dihalogeno-3,3,4,4-tetrafluoro-cyclohexanes (2). Here 1,2,3-trihalogenated structure of the resulting benzenes is determined by the most facility to elimination of hydrogen at the 2-position of carbocycles (4).

## AROMATIZATION OF CHLOROTRIFLUORO- AND TETRAFLUOROCYCLOHEXENES

*M.B. Lipkind, N.V. Volchkov, O.M. Nefedov*

*Zelinsky Institute of Organic Chemistry, Russian Academy of Sciences, Leninsky Prospect, 47, Moscow 117913, Russia.*

Aromatization in the presence of a different dehydrohalogenating agents and under gas phase pyrolysis conditions for chlorotrifluoro (1)- and tetrafluorocyclohexenes (2) prepared from dienes and chlorotrifluoroethylene or tetrafluoroethylene has been investigated

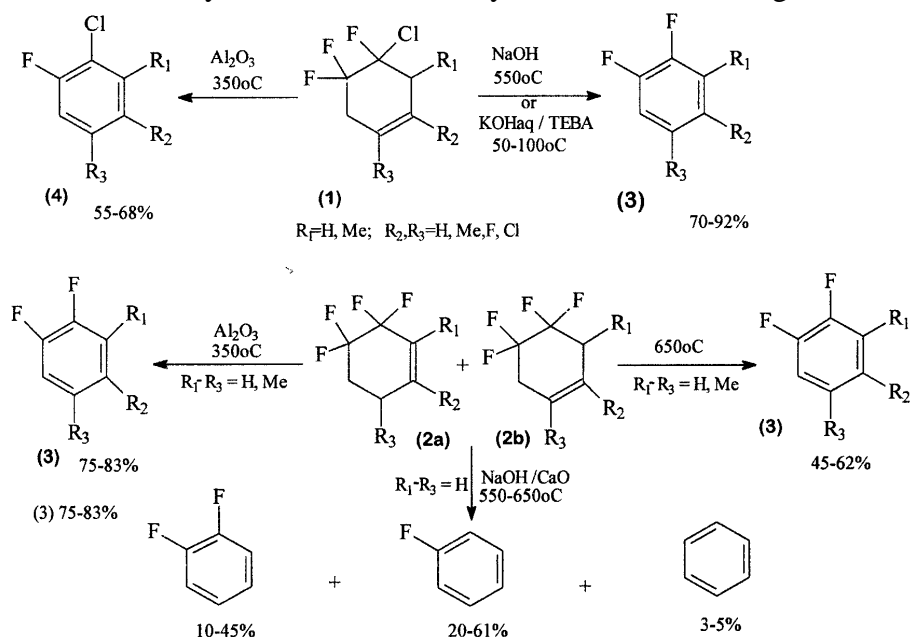

The thermal aromatization both of (1) and (2) in a flow reactor at 600-670°C gives difluorobenzene derivatives (3) in 45-63% yields. Aromatization of (1) by action of solid alkalis (NaOH/CaO) in a gas phase at 470-550°C or in a liquid phase under PTC conditions at 50-100°C gives difluorobenzenes (3) as major products (70-92% yields) and 6-20% of chlorofluorobenzenes (4). However, in the presence of alumina the dehydrofluorination of (1) to (4) is a main reaction. Tetrafluorocyclohexenes (2) may be selectively converted to (3) by action of Al<sub>2</sub>O<sub>3</sub>, whereas in the presence solid alkalis both dehydrofluorination and defluorination may take place.

### KINETICS OF THE THERMAL ISOMERIZATION AND FRAGMENTATION OF FLUORINATED VINYL CYCLOBUTANES

*O.M. Nefedov, A.I. Shipilov, N.V. Volchkov, V.F. Zabolotskikh*

*Zeiinsky Institute of Organic Chemistry, Russian Academy of Sciences, Leninsky Prospect, 47, Moscow 117913, Russia, Perm Department of RSC "Applied Chemistry", Voronezhskaya str., 41, Perm 614034, Russia*

Kinetic features of the thermal ring-expansion and fragmentation of fluorinated vinylcyclobutanes 1a-c has been investigated

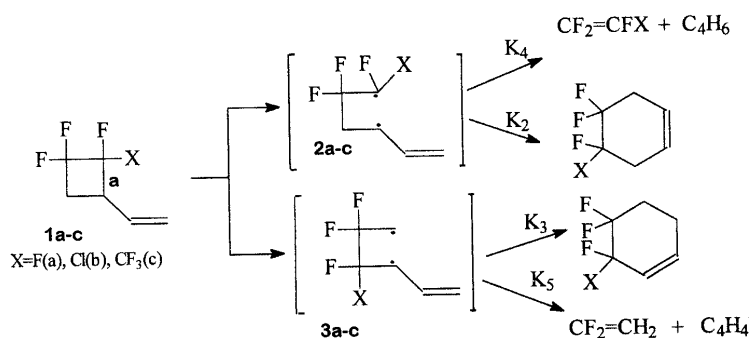

The experiments have been carried out in a flow quartz reactor in the temperature range 844 - 927K.

The obtained kinetic data are consistent with a homolytical mechanism involving first competitive breaking cyclobutane bond (a) or bond (b) followed by C6-cyclization or fragmentation of intermediates allyl diradicals 2 or 3. The observed regioselectivity and distinction in the activation parameters characteristics for 1 a, 1 b and 1 c are in accordance with a different ability of fluorine, chlorine and trifluoromethyl group to stabilize allylic diradicals

X	Activation parameters characteristics for rate constants									
	K1		K2		K3		K4		K5	
	lgA	Ea	lgA	Ea	lgA	Ea	lgA	Ea	lgA	Ea
F	13,8	51,8	12,6	51,5	13,0	50,1	-	-	14,0	54,1
Cl	13,5	48,2	12,5	46,2	-	-	13,35	50,9	12,2	50,4
CF3	13,9	52,5	12,4	47,9	-	-	13,3	51,6	12,7	53,0

## FLUORINATED VINYL-CYCLOBUTANES AND VINYL-CYCLOBUTENES IN THE REACTIONS WITH NUCLEOPHILIC AND ELECTROPHILIC REAGENTS

V. Volchkov, M.B. Lipkind, I. B. Shvedova, O.M.Nefedov

Zelinsky Institute of Organic Chemistry, Russian Academy of Sciences Leninsky Prospect, 47, Moscow 117913, Russia

Fluorinated vinylcyclobutanes and vinylcyclobutenes are available polyfunctional synthons which may react with the assistance of four-member saturated or unsaturated carbocycles and exocyclic double bonds

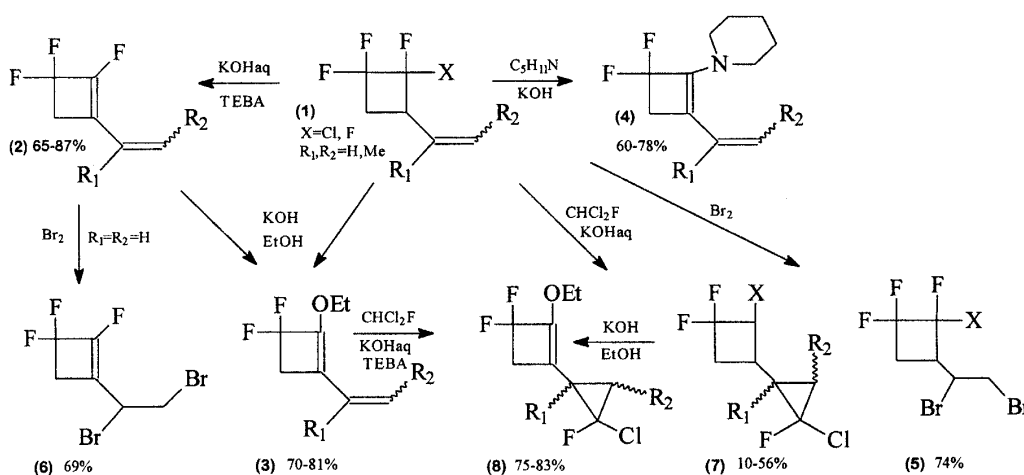

Thus, vinylcyclobutanes (1) may be easily converted to cyclobutenes (2) by dehydrohalogenation under PTC condition in the presence of aqueous KOH. When an alcoholic KOH has been used as a dehydrohalogenating reagent or the reaction has been carried out in the presence of piperidine, ethoxycyclobutenes (3) or piperidylcyclobutenes (4) are obtained as a result of a primary dehydrohalogenation of (1) to (2) and following combination of the reaction of nucleophilic addition and dehydrofluorination with the assistance of an endocyclic double bond in cyclobutenes (2).

On the contrary, the electrophilic reactions (bromination and cyclopropanation) of both vinylcyclobutanes (1) and vinylcyclobutenes (2) selectively proceed over the exocyclic unsaturated fragment to form dibromides (5) or (6) and cyclopropane derivatives (7) or (8). The reactivity of the exocyclic double bond of vinylcyclobutenes, relative to dihalogenocarbene cycloaddition, greatly increases when an electron-donating ethoxy group has been introduced into the conjugated endocyclic bonds instead of fluorine.

## SYNTHESIS OF FLUOROAROMATIC COMPOUNDS FROM FLUOROALKENES AND DIENES. THERMAL ISOMERIZATION AND AROMATIZATION OF FLUORINATED VINYL-CYCLOBUTANES

*N.V. Volchkov, M.B. Lipkind, O.M. Nefedov Zeiinsky Institute of Organic Chemistry, RAS, Leninsky Prospect, 47, Moscow 117913, Russia*

Polyfluoroolefines thermally react with dienes to form vinylcyclobutanes (I) which can be used as useful intermediates for synthesis of fluorinated six-membered cyclic compounds and fluoroaromatics [1-5]

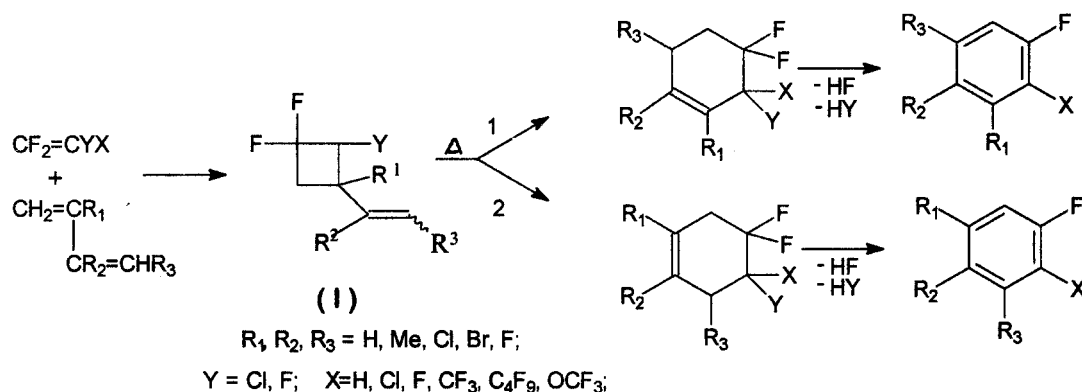

The selectivity of these syntheses depends on the substituent at the 2-position of the cyclobutane ring. That, the thermal isomerization of tetrafluorocyclobutanes (I) ( $X=Y=F$ ) proceed in preference via breaking bond C1-C4 (route 1) while chloro- and perfluoroalkyl-substituted (I) ( $X=F, Y=\text{Cl, CF}_3$  or  $\text{C}_4\text{F}_9$ ) prefer to break off bond C1 - C2 (route 2) [3,4]. Using this regioselectivity of ring-expansion of (I) and selective dehydrohalogenation agents, easy two- or three-steps regioselective synthesis of a variety fluorobenzene derivatives, among them 1,2-difluorobenzene, 3,4-difluorotoluene, 2,3-difluoro-toluene, 2,4,5-trifluorotoluene, 2,3-difluoro-chloro-benzene, 2,3-difluorobromobenzene, 2-fluorobenzotrifluoride from available fluoroalkenes and dienes has carried out.

### References

1. Nefedov O.M., Politansky S.F., Ivashenko A.A., Lipkind M.B., Strashnenko A.V., Veremy B.N., Inventor's Certificate USSR, N 869242. (1981).
2. Volchkov N.V., Lipkind M.B., Politansky S.F., Nefedov O.M., Shaidurov V.S., Zabolotskich V.F., Shipilov A.I. Inventor's Certificate USSR, N 1380189 (1986).
3. Lipkind M.B., Volchkov N.V., Shipilov A.I., Zabolotskich V.F. In.: 6th All-Union Conference on Chem. of Organo-fluorine Compounds, Abstracts, Novosibirsk, 1990, p.26.
4. Nefedov O.M., Volchkov N.V., Zn. Org. Khim., 1994, v. 30, N 8, pp. 1123-1135.
5. Weigert F.J., Davis R.F.J. Fluorine Chem., v.63, h. 59-84.

## SOLVENTS EFFECTS ON FLUORINATION WITH REAGENTS-TRANSFERRES OF FLUORINE. A QUANTITATIVE EVALUATION

*A. A. Fainzilberg and V.N. Solkan*

*Zeiinsky Institute of Organic Chemistry, Russian Academy of Sciences, Leninsky Prospect, 47, Moscow 117913, Russia*

As a continuation of our systematic researches on chemistry of transferrers-fluorine, the quantitative approach to estimation of influence of the solvents on fluorinating ability of these - reagents have been developed. The work has been carried out with the help of semi-empirical quantum-chemical method (MINDO PM3) using model of a polarized continuum.

Enthalpy of formation of fluorinating reagents of the specified type in a solution and in gas phase were determined and thermal effects of chosen model reaction of fluorination in solvents of various polarity are estimated. Pyridine was chosen as a substratum (an object of fluorination); it allows not only to compare fluorinating ability of various fluorine carriers but also simultaneously to answer a question, whether they are better or worse than such a popular fluorinating reagents as N-fluorine pyridine. Received data evidently demonstrate in the quantitative form essential change in fluorinating ability of electrophilic reagents depending on polarity of the solvent.

The suggested scale of thermal effects is symbatic to the changes in electrochemical values  $E_p$  (reduction on bond N-F), which were experimentally determined by other authors and characterize relative reactivity of fluorinating reagents. Our data indicated N-fluoro-bis-(trifluoromethylsulfonyl) imide and 1-chloromethyl-4-fluoro-1,4-diazoniabicyclo[2.2.2]-octane salts as most active.

As a whole, an approach offered in the work not only deepens the process of fluorination, but also enables quantitative forecast of reactionary ability of fluorinating reagents, including the new ones, in planed real experimental condition.

This approach needs neither synthesis of reagents nor experimental study on their properties. The answer can be given fast by means of calculation done using the program developed by us.

### **$\omega$ -BROMOPERFLUOROALKYL VINYL ETHERS - STARTING FLUOROOLEFINES FOR SYNTHESIS OF FLUORINATED VINYL ETHERS WITH FUNCTIONAL MOIETY**

*V.M.Andryushin, N.B.Pavlova, L.M.Popova, A.B.Kosarev, N.A.Ryabinin, B.N. Maksimov RSC "Applied Chemistry", 14 Dobrolubov ave., 14197198, St.Petersburg, Russia*

In the last years the fluorinated plastics and rubbers are widely useful in different branches of technology. These materials must to have the high termo-, chemical-, acid-, alkali-, oil-resistance. The production process of these materials mainly based on the using of tetrafluoroethylene (TFE) and other olefins. Desirable physic-chemical and physic-mechanical and other parameters achieved by means of creation of copolymers with different structure.

The new procedure for preparing of various fluorocontaining ionoexchained membranes (FIEM) based on the using of  $\omega$ -bromoperfluoroalkylvinyl ethers  $\text{Br}(\text{CF}_3)_n\text{CF}_2\text{OCF}=\text{CF}_2$  (I) as comonomers was elaborated. The carboxylfluoromonomer FK-96 requirable for production of membranes in chloro-alkali-electrolisis was synthesed with high yields and purity up to 99.9%.

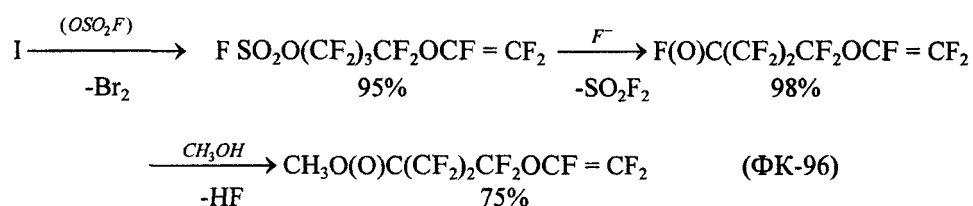

The monomers was testing in JCS "Plastpolymer" with positive results.

In this work we are carried out the synthesis of series the fluoromonomers with anionogenic groups (II) according to the following scheme:

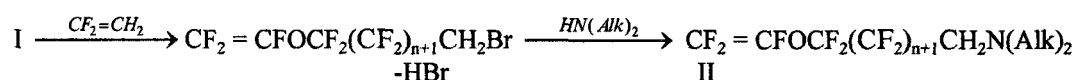

The yields of (II) achieved 10-15%.

The polymer, making from this alkylaminoderivative (II), no provided for required parameters because (II) has low reactivity on the copolymerisation process with tetrafluoroethylene, probably, due to the presence of the alkylaminogroup. Desired fluoropolymer with high containing of anionogenic groups was prepared from the sequence of polymeranalogic transformation of bromine in TFE-(I) copolymer.

## NEW APPROACH TO CREATION OF IONOGENIC FUNCTIONAL FLUOROPOLYMERS

*V.M.Andryushin. N.A.Dreyman\*, N.B.Pavlova, L.M.Popova, P.M.Chekmarev\*, N.A.Riabinin  
RSC "Applied Chemistry", 14 Dobrolubov ave., 197198, St.Petersburg, Russia \*JCS  
"Plastpolymer", Russia 195108, St.Petersburg, 32 Polyustrovskiy pr.*

Unfortunately, traditional methods of copolymers formation contained ionogenic fragments, i.e. tetrafluoroethylene (TFE), vinylidene fluoride (VF) etc. with fluoroolefines possessing various functional groups, can't lead to desirable results in any cases. So, several attempts to synthesize of ionogenic groups contained fluoroplast appears unsuccessful in account of low activity of TFE and VF and in copolymerisation processes with ~CH<sub>2</sub>N(Alk)<sub>2</sub>-capped fluorosubstituted vinyl ethers.

We have now developed a procedure of ω-bromoperfluoroalkylvinyl ethers based fluoroplasts possessing ionogenic groups synthesis in which the interaction between these ethers and TFE (VF) gives copolymers with 25-26% mol. of the bromomonomer. Further required functional structure formation was results of the sequence of polymer-analogic transformations. Most active anions are synthesised according to the following scheme:



The main dependencies of this process were studied and produced films were tested in electrolysis cell. It was estimated that new fluoroplastes possess excellent anionic conductivity and chemo-, acido- and oxi-resistance at high temperature.

Similarly studies were carry out with carboxylic ionoexchanged membranes (IEM) in order to replace the FK-96 monomer.

IEM was produced from the treatment of films or beads of the TFE-ω-bromoperfluoroalkylvinyl ethers copolymer according to the scheme:

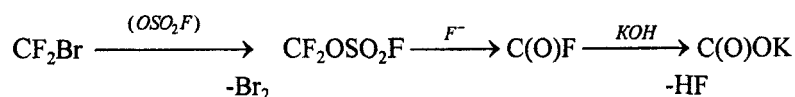

Optimal conditions of the process determined and physic-chemical, physic-mechanical and special properties of these membranes were investigated.